

Endurant XD Series (Endurant XD and Endurant XD Pro) Automated Transmissions TRIG0960 EN-US

October 2024



BACKED BY
Roadranger
SUPPORT

Important Information	1	Section 7: Electrical System Requirements	29
OEM Design Package	2	Power Requirements	29
Other Useful Publications	2	Mating Connector and Terminal Requirements ...	30
Acronyms Associated with Endurant XD Series ...	2	Electrical Sealing Requirements	30
Section 1: Introduction and General Information ...	3	Network Communication Requirements	30
System Features and Familiarization	3	Vehicle Service Requirements for Electronics ...	31
Transmission Components Temperature		OEM Interface Connections	31
Requirements	4	20-Way Vehicle Connector	32
Clutch and Transmission Identification	4	20-Way Body Connector	34
254mm Damper	5	Configurable I/O	35
285mm Damper	5	Configuration procedure	35
Section 2: Component Weight and Center of Gravity .	7	Fluid Pressure Sensor	36
Clutch Assembly	7	Driver Interface Device (DID)	37
Transmission Assembly 651 lb (295.3 kg)	7	Typical Start Enable Relay	39
Section 3: Vehicle Space Claim	8	Control Area Network (CAN) Communications ...	40
Clutch Dimensions	8	Section 8: Electrical Wiring Recommendations ...	41
Transmission Dimensions	9	Electrical Contact Lubrication Recommendations .	41
PTO Mounting Locations	10	Harness Design Recommendations	41
Driver Interface Device Space Claim	10	Electrical Juncture Recommendations	41
Shift Controller Label	10	Section 9: Harness Routing and	
Section 4: System and Feature Integration	11	Clipping Requirements	42
Vehicle System Integration (VSI) Group	11	Predetermined Clipping Points	43
Required Feature Integration	12	Section 10: PTO Inputs and Configurations	44
Optional Feature Integration	19	Section 11: OEM Assembly Procedures	45
Power Take-Off (PTO) over J1939	20	Suggested Installation and Diagnostic Tools ...	45
Auxiliary Transmission Integration	20	Component Packaging and Handling	46
2-Speed Axle Integration	21	Clutch Installation	50
Rock-Free	21	Control Finger Detail	52
Secondary Configuration Mode	21	Transmission Preparation and Installation	53
Reverse Output Signal	21	PTO Installation	53
Neutral (Range) Output Signal	21	Mounting Transmission to Engine	54
Force/Hold Neutral	22	Pull-to-Neutral and Clutch Actuator Unlock ...	55
Oil Cooler Provision and		Transmission Lubrication	56
Performance Requirements	22	Lubrication Fill Procedure	57
Section 5: Lubrication Requirements	24	Verifying Lubrication Level in Vehicle	57
External Oil Filter	24	Pneumatic Connections	58
Section 6: Pneumatic System Requirements	25	Electrical Connections	58
Supply Pressure	25	OEM Interface Harnesses to TCM	59
Air Consumption	26	Vehicle Equipment Programming Station (VEPS) .	59
Air Quality	27	Grade Sensor Calibration	60
Air Supply Requirements	27	End-of-Line Operation	60
		Assembly Review Process	61
		Diagnostic Procedure	67
		Troubleshooting and Test	
		Equipment Recommendations	69
		Change Log	70

Important Information

This symbol is used throughout this manual to call attention to critical information where failure to adhere to safety specifications may result in personal injury and/or component damage.

Departure from the instructions, choice of tools, material or recommended parts mentioned in this publication may jeopardize safety.

Safety Requirements:

Safety related requirements placed on the vehicle system by the transmission. Failure to comply may disable key and/or redundant safety features of the transmission system.

 **DANGER:** Failure to follow indicated procedures will result in death or serious injury.

 **WARNING:** Failure to follow indicated procedures and/or safety requirements could result in death or serious injury.

NOTICE: Failure to follow indicated procedures could result in damage to the transmission system.

 **WARNING:** While working on a vehicle, do not modify transmission components or systems. Modification (altering, substituting, relocating) of transmission components may result in major vehicle component damage, severe injury or death.

This publication has been assembled to assist the original equipment manufacturer (OEM) with proper design integration, handling and assembly of the Endurant XD transmission. For additional information such as transmission operation, troubleshooting and warranty information, please see the Other Useful Publications section in this manual.

The Endurant XD system is designed to operate correctly and safely when the requirements in this installation guide are met, in particular unintended or incorrect system operation could occur if requirements marked as a safety requirement are not complied with.

Transmissions installed at OEM facilities shall meet all requirements as identified in the Application Guidelines TRAG2600 and be approved by Eaton Application Engineering. Contact your OEM Application Engineering department or Eaton Application Engineering for the proper Application Approval Form. All applications shall be submitted for approval.

Endurant XD transmissions are only compatible with engines as certified by Eaton Cummins Automated Transmission Technologies. For specific engine information, please contact the engine manufacturer.

Failure to adhere to installation requirements or any handling and installation requirements may affect transmission performance and/or warranty coverage.

Any reference to brand names in this publication is made as an example of the types of tools and materials recommended for use and should not be considered an endorsement. Equivalents may be used.

Every effort has been made to ensure the accuracy of the information contained in this manual. However, Eaton and Eaton Cummins Automated Transmission Technologies makes no warranty, either expressed or implied, based on the information provided and reserves the right to discontinue or modify models and/or procedures and to change specifications at any time without notice.

The vehicle OEM shall be responsible for producing parts that meet the requirements of this document.

OEM Design Package

The OEM shall submit a design package to Eaton Cummins Automated Transmission Technologies OEM customer support engineering for approval prior to any build.

A design package consists of the following information:

- Detailed drawing of battery power and ground scheme.
- Construction detail of individual wiring harnesses including harness routing location and clipping points.
- Specifications for air dryer, air compressor and filter filtration systems.
- A high-level schematic of the pneumatic system supplying the transmission.

NOTICE: The Endurant XD Series system requires passive sealing on the clutch housing to ensure no foreign debris enters the clutch area. The OEM shall ensure that all openings in the engine flywheel housing are sealed.

Other Useful Publications

- Eaton Transmission Application Guidelines TRAG2600
- Eaton Automated Transmission Engine Configuration Settings Guide TRIG0910
- Eaton Lubrication Manual TCMT0021
- Eaton Approved Lubricant Supplier Manual TCMT0020
- Eaton Cummins Automated Transmission Technologies Endurant XD Series Troubleshooting Guide TRTS0960
- Eaton Cummins Automated Transmission Technologies Endurant XD Series Driver Instructions TRDR0960
- Eaton Cummins Automated Transmission Technologies Endurant XD Series Service Manual TRSM0960
- Eaton Cummins Automated Transmission Technologies Warranty Guide TCWY0900
- ISO Compressed Air Standard ISO 8573-1:2010(E)

Acronyms Associated with Endurant XD Series

- TCM: Transmission Control Module
- MTM: Mechatronic Transmission Module
- LCA: Linear Clutch Actuator

Section 1: Introduction and General Information

System Features and Familiarization

Integration Features:

- 12-volt vehicle electrical system capable
- SAE No. 1 diameter clutch housing and conventional bolt pattern
- 18-tooth input shaft and pre-installed clutch release yoke and release bearing for single plate, self-adjusting, 430mm diaphragm spring clutch with organic facings
- Bottom mount 8-bolt PTO and rear 4-bolt PTO with pressurized oil port for external lubrication and cooling are standard
- 16 predetermined points for OEM harness routing and clipping, including 7 pre-tapped support bosses for PTO support brackets
- Provision for rear transmission support
- Provision to support remote mounted oil coolers when required by the application

System Performance Features:

- Intelligent start gear selection and shift strategy automatically selects appropriate gear based on percent grade, vehicle weight and engine torque
- Intelligent urge to move managed based on brake switch and grade inputs
- GearLogic™ technology standard such as neutral-coast and hill start aid
- Integrated transmission lubrication pressure and temperature monitoring to prevent system damage

Mechanical Performance Features:

- Pneumatically operated gearbox and clutch actuators
- Mechatronic transmission module (MTM) combines integration of actuation and sensors
- Precision lube technology optimized to reduce churning losses and enhance fuel economy performance while reducing maintenance costs with lower fill volumes
- Integrated oil bypass valve to prevent overcooling and improve efficiency when a transmission oil cooler is used
- Twin countershaft, helical gearing with no 4-mesh condition in high range for improved efficiency and a cooler running transmission

Diagnostic Features:

- Supported by Eaton ServiceRanger PC-based service tool
- Compatible with Eaton IntelliConnect™ remote diagnostics

Transmission Components Temperature Requirements

The Endurant XD Series is capable of sustained operation at oil temperatures up to 250 °F (121 °C).

The Endurant XD Series must not be operated at temperatures above 275 °F (135 °C). Operation at oil temperatures above 275 °F (135 °C) causes transmission damage.

Operation with the transmission oil temperature between 250 °F (121 °C) and 275 °F (135 °C) should be kept below 1% of average operating time, excess operating time will reduce the operational life of transmission components. 1% of operating time is on average 6 minutes in a 10-hour shift but is averaged across all operational time allowing for longer period of times based on seasonal weather or abnormal use cases but should never exceed 30 consecutive minutes.

The temperature limit for all electrical and air system components is 221 °F (105 °C). If sufficient air gap between the heat source and the following transmission components cannot be achieved, the OEM must provide proper methods of heat shielding to ensure this limit is not exceeded. The components and systems to be protected include, but are not limited to, the mechatronic transmission module, transmission control module, linear clutch actuator, lubrication sump, and output speed sensor harness.

Clutch and Transmission Identification

Clutch Assembly

The Endurant XD Series master clutch assembly is a single plate diaphragm spring self-adjusting clutch with 430mm OD organic clutch disk facings. This clutch is a push-to-release type which differs from legacy heavy duty Eaton clutches which are pull-to-release type. Pre-adjustment of the clutch assembly is not necessary once installed to the engine flywheel. Endurant XD Series may be equipped with clutch assemblies having either 254mm damper or 285mm damper. This size refers to the outer diameter of the clutch damper that fits within the engine flywheel bore. These 2 clutch assemblies are each uniquely designed to pair with the transmission models listed in the table below:

Transmission	Clutch Description	Damper Style (engine/flywheel dependent)	
		254mm	285mm
EXD-16F118D, EXD-18F118D	Standard	105510-5	105520-20
EXDP-16F118D, EXDP-18F118D	Extreme Duty	105550-CL-70	105560-60
EXDP-20F118D	High Torque, Extreme Duty	105550-CL-65	105560-65

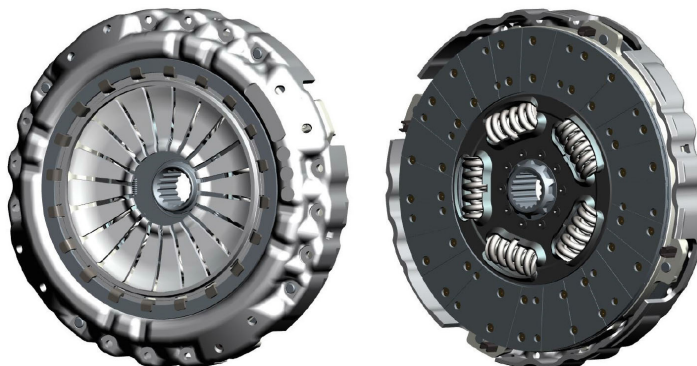

254mm Damper



285mm Damper

Transmission Assembly

The Endurant XD Series is an automated 18-speed twin countershaft transmission. Endurant XD Series is pneumatically shifted with high efficiency gearing, precision lubrication, lightweight aluminum enclosures, and features GearLogic™ software.

Following is a nomenclature tree that describes the multiple configurations of the transmission model numbers:

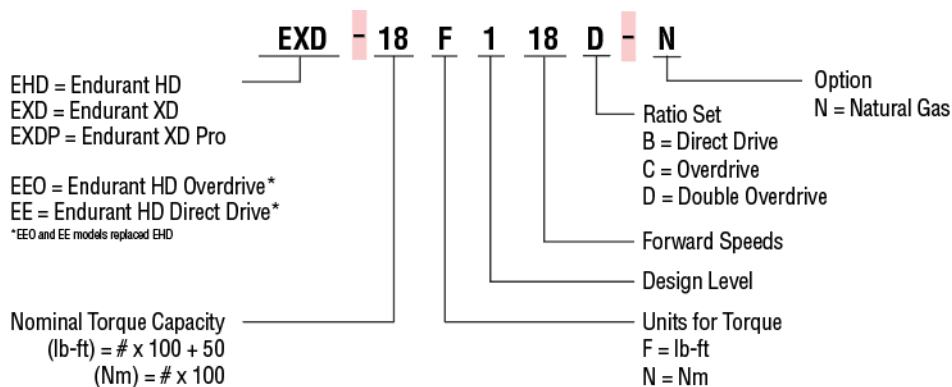

All Endurant XD Series transmissions are supplied with component identification tags which define the transmission model number, assembly number and serial number. Identification tags are located on the lower right side of the clutch housing.

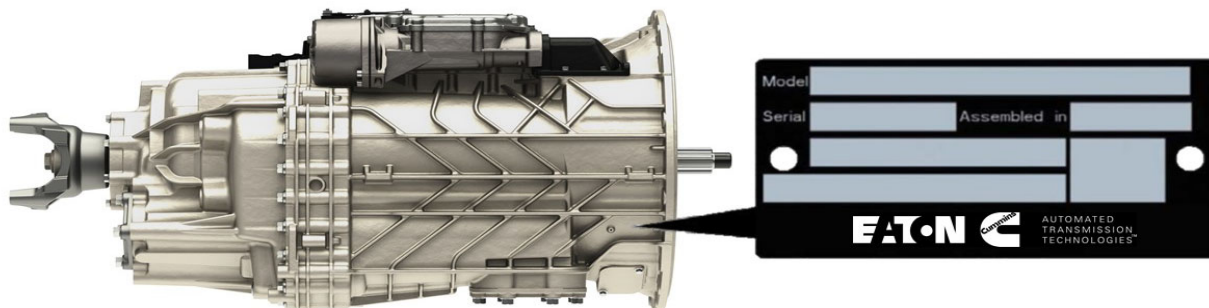

Transmission Assembly

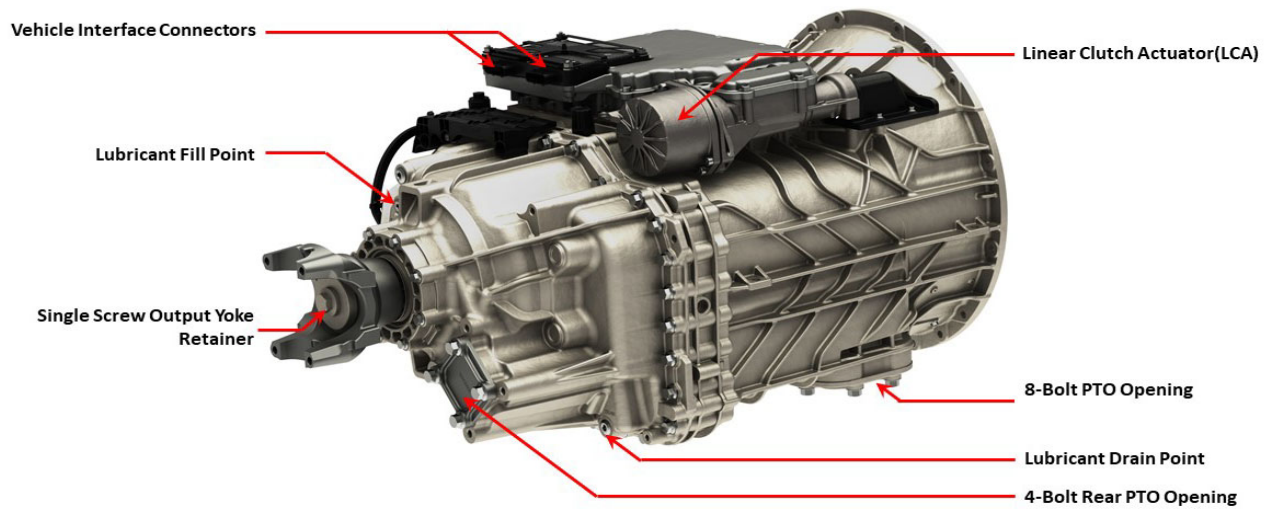
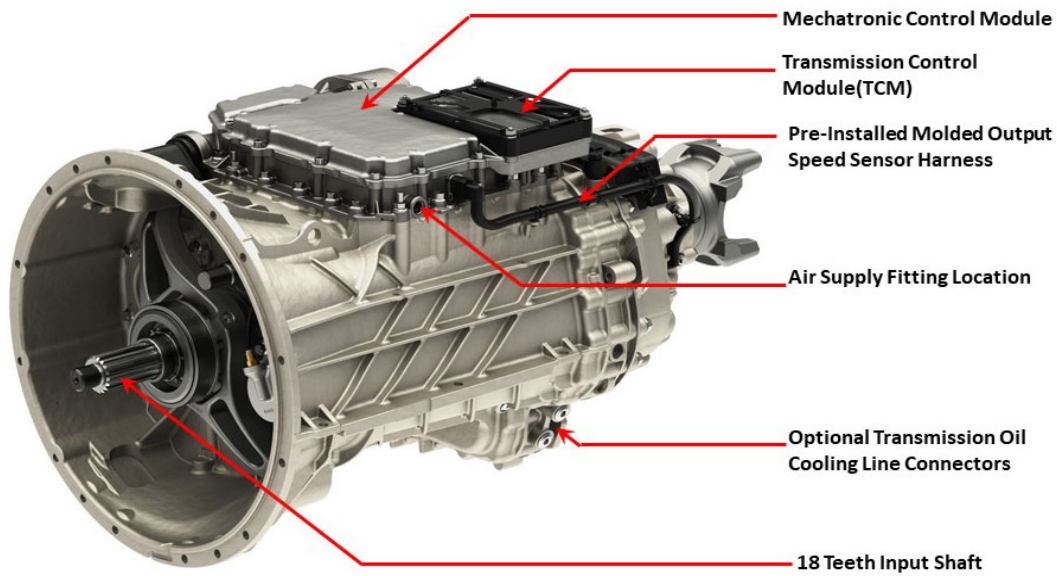

Section 2: Component Weight and Center of Gravity

Clutch Assembly:

Transmission	Clutch Description	254mm	285mm
EXD-16F118D, EXD-18F118D	Standard	116 lb (53kg)	119lb (54kg)
EXDP-16F118D, EXDP-18F118D	Extreme Duty	116 lb (53kg)	124 lb (56 kg)
EXDP-20F118D	High Torque, Extreme Duty	119 lb (54kg)	124 lb (56 kg)

Transmission Assembly: 651 lb (295.3 kg)

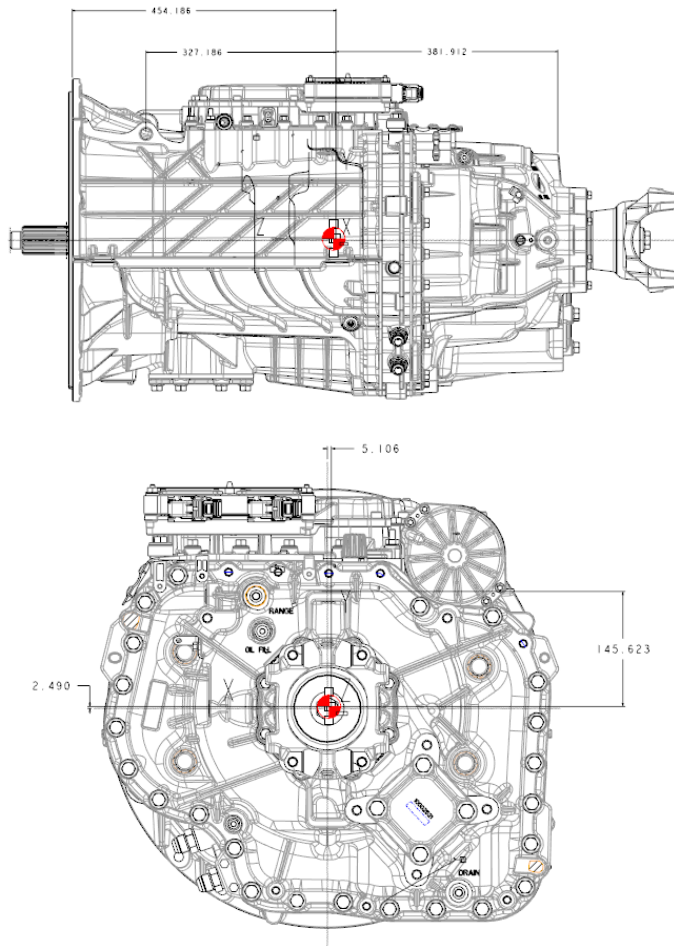

Note: The above picture shows one possible combination of clutch, input shaft and output yoke assembly. Several combinations of input shaft lengths and output shafts also exist. Please refer to Transmission Dimensions for further details.

Section 3: Vehicle Space Claim

Clutch Dimensions

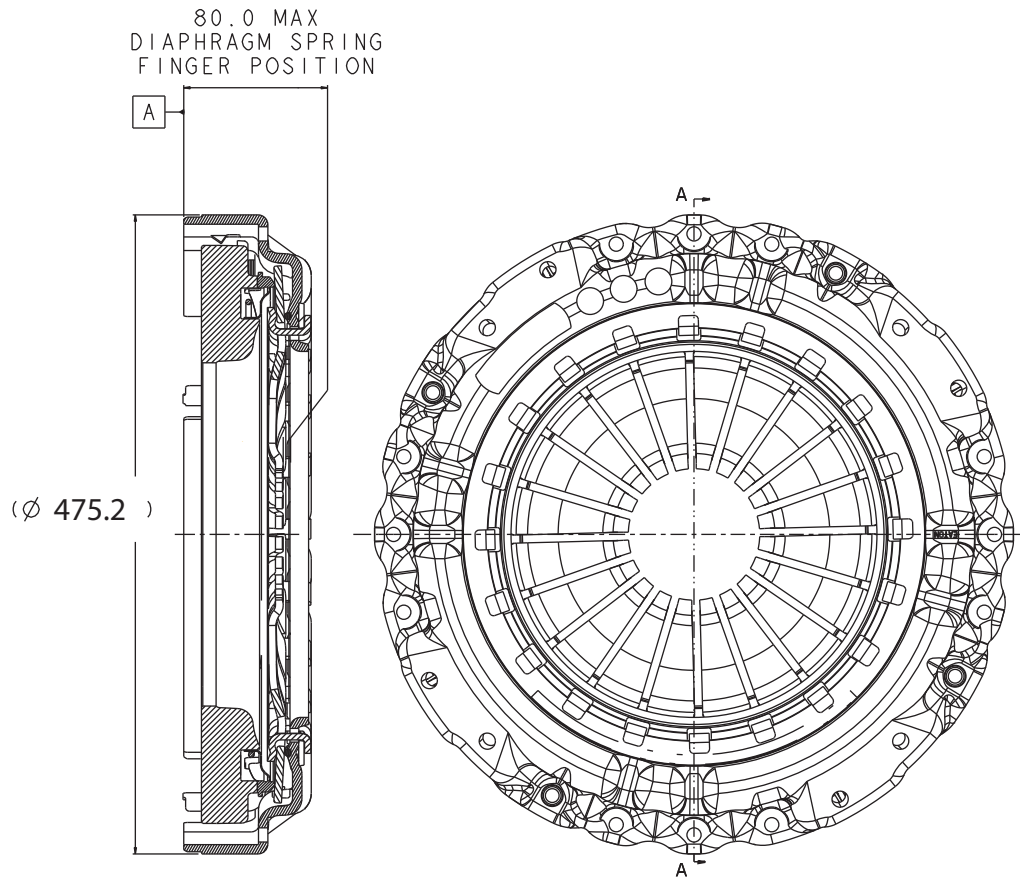

Note: Endurant XD Series can be configured with multiple clutch options. The dimensions shown above are the same for all the clutch models.

Transmission Dimensions

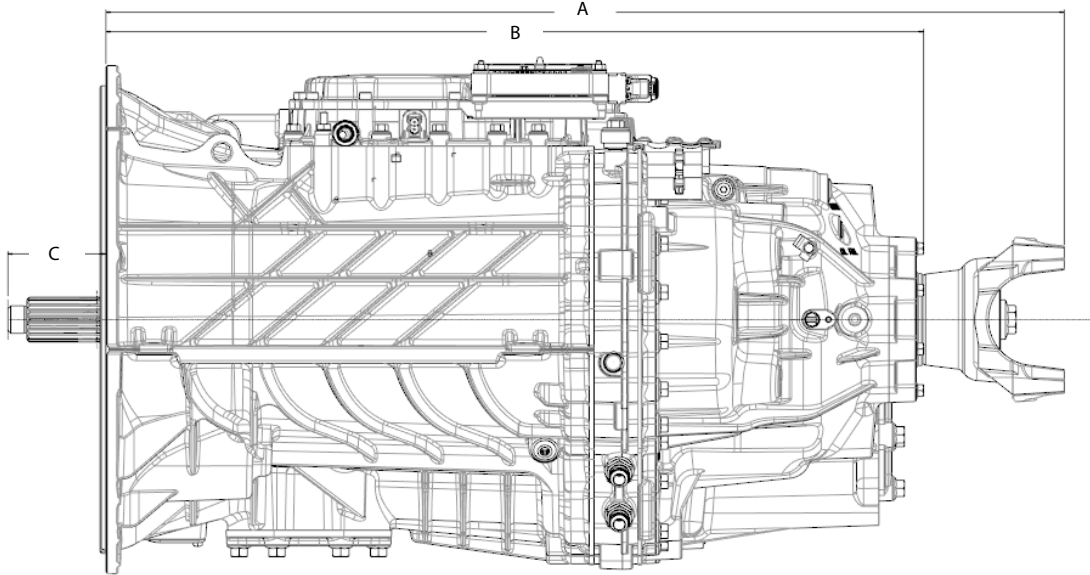

Transmission Dimensions Table:

Dimension	Value (mm)	Additional Notes
A	1048.0	
B	892.6	To the seating surface of the output yoke
C	113.3 +0.00/-2.84	For Input Shaft 10003512
	104.5 +0.00/-2.84	For Input Shaft 10004048

Note: Endurant XD Series can be configured with multiple lengths of input shaft options and multiple types of output shaft yoke assemblies. One of the combination is shown in the picture for reference. Please refer to OEM installation print 5587300 for further details.

PTO Mounting Locations

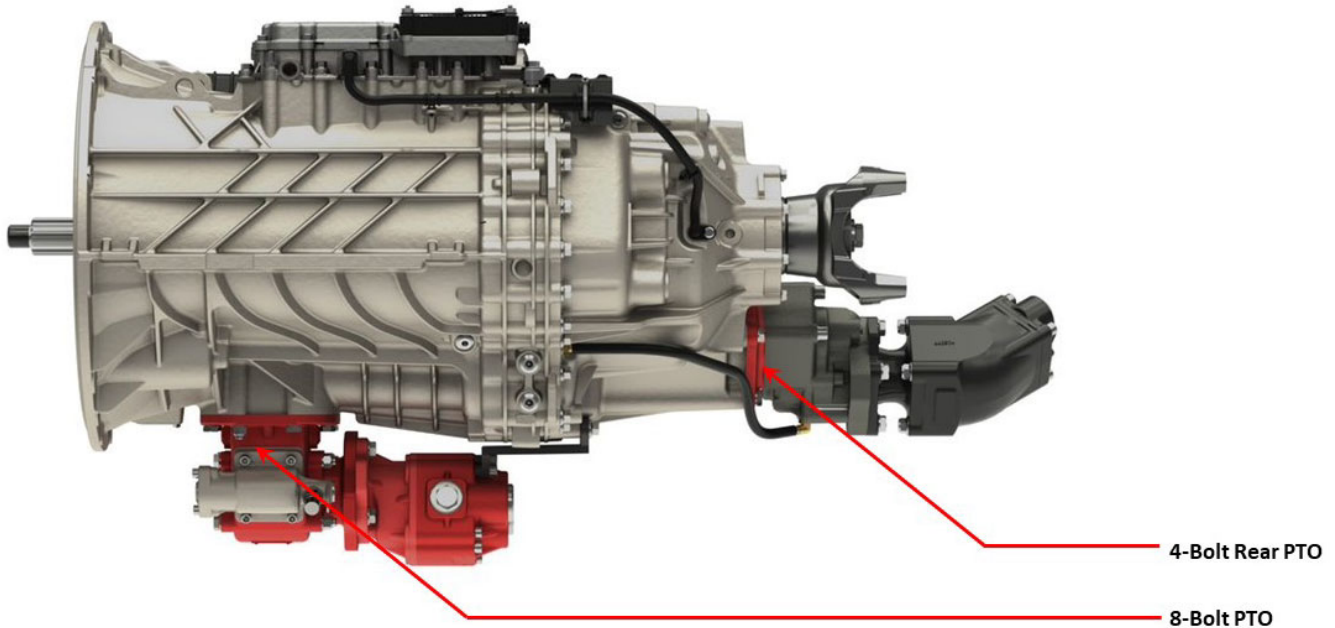

Driver Interface Device Space Claim

The Endurant XD Series driver interface device, or shift controller, does not have an established space claim for the vehicle. The OEM is responsible for furnishing an appropriate driver interface device and corresponding space claim(s).

The driver interface device is not limited to a single device and may be multiple devices such as a stalk-type controller on the steering column in combination with a dash mounted switch.

Shift Controller Label

There are no supplied shift labels available for the Endurant XD Series transmission. Furnishing of a shift label is the responsibility of the vehicle OEM as it must reflect information specific to the OEM supplied driver interface device.

Eaton Cummins Automated Transmission Technologies recommends a shift label containing the following transmission specific information. This information is not required to be identified as a Warning.

- Transmission make and model, number of forward and reverse speeds.
- That transmission air supply pressure of 90 psi (5.9bar) or greater is required for non-neutral engagement.
- Not to operate the vehicle if an alternator lamp or gage indicates low voltage.
- OEM specific instruction on how to start the vehicle and engage a forward or reverse gear.

Section 4: System and Feature Integration

Vehicle System Integration (VSI) Group

Integration requirements for the features identified in this section are maintained by Eaton Cummins Automated Transmission Technologies VSI group in what is known as a Truck System Integration (TSI) documents. The TSI documents can vary by OEM, model year and transmission model. The TSI documents are also used to document interfaces with OEM proprietary. Integration of new features or integration of existing Eaton Cummins Automated Transmission Technologies products to new vehicle platforms should be discussed with Eaton Cummins Automated Transmission Technologies VSI group to identify the relevant requirements or to generate new requirements.

The list below identifies the system features for which all integration requirements are maintained as TSI documents. A brief description or high level requirement of each feature is provided and each feature is identified as “required” or “optional.”

Required: The OEM design shall meet all system integration requirements in order for the Endurant XD Series system to operate correctly and safely and to avoid unintended or incorrect system operation.

Optional: The OEM has the option to integrate each feature as desired.

Required Feature Integration:

Engine

 **WARNING:** This is a safety requirement. To protect against malfunctioning ECUs, certified engines shall operate with set upper limits on duration of TSC1 torque control requests. Additionally the engine shall receive and monitor a rolling counter (SPN4206) and checksum (SPN4207) in issued TSC1 requests to evaluate the sending ECUs health. Failure to monitor sending ECU health and limit TSC1 duration has potential to result in unintended vehicle acceleration, which may result in serious injury or death.

 **WARNING:** This is a safety requirement. The engine Speed (J1939 EEC1 message) signal has the ability to inhibit or delay clutch disengagement and prevent speed rationality checks performed by the transmission. The vehicle system shall diagnose the Engine Speed (J1939 EEC1 message) signal sent to the transmission TCM and ensure its integrity. Failure to diagnose in range failures of the Engine Speed (J1939 EEC1 message) signal has the potential to increase vehicle stopping distance due to delayed driveline disengagement or reduced ability to move the vehicle from adverse conditions, which may result in serious injury or death.

 **WARNING:** This is a safety requirement. The Engine Idle Speed (J1939 EC1 message) value has the ability to negatively influence clutch disengagement if it is 10rpm or more below than the actual engine idle governor control point used by the engine ECU. The vehicle system shall provide Engine Idle Speed (J1939 EC1 message) value that is identical to the control point of the engine idle speed governor. Failure to broadcast a Engine Idle Speed (J1939 EC1 message) value that is identical to the true idle control point has the potential to increase vehicle stopping distance due to delayed driveline disengagement, which may result in serious injury or death.

Endurant XD Series transmissions are only compatible with engines as certified by Eaton Cummins Automated Transmission Technologies. The engine ECU shall contain the proper configuration settings for Endurant XD Series transmission operation.

All required engine ECU settings can be found in the Eaton Automated Transmission Engine Configuration Settings Guide, publication number TRIG0910. The publication can be found in the Literature Center at www.roadranger.com.

For specific engine information, please contact the engine manufacturer.

Calibration File

To achieve designed performance levels and activation of some features, the Endurant XD Series transmission requires a calibration file to be installed onto the TCM in addition to the application software. For production vehicles the calibration file is installed at the OEM Vehicle Equipment Programming Station (see VEPS section for more information), in-service vehicles can have the calibration files changed with the ServiceRanger service tool. Without a calibration file the transmission will have limited functionality and will broadcast active fault SPN 629, FMI 13.

Calibration files contain parameters developed by Eaton Cummins Automated Transmission Technologies calibration engineers that are vehicle configuration specific and are certified under an Eaton Cummins Automated Transmission Technologies part number. Calibration files may contain, but are not limited to, shift point maps, engine tuning parameters and OEM specific tuning of features such as Urge to Move. See VEPS in Section 11 for more information.

Flywheel and Pilot Bearing

Flywheel

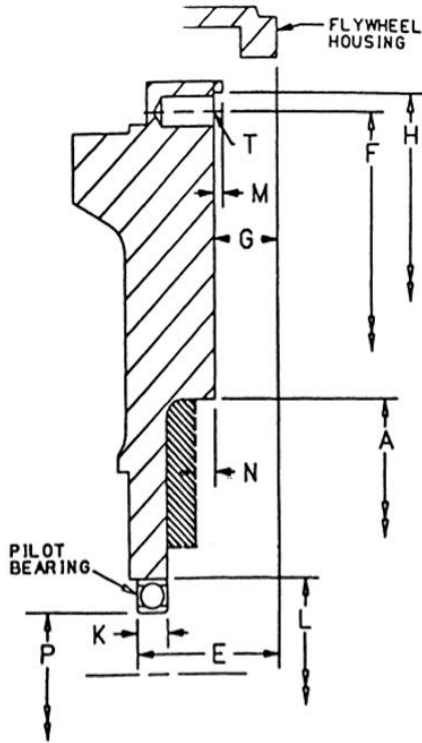

Dim	For 254mm Clutch Damper models (mm)	For 285mm Clutch Damper models (mm)	Notes
A	Ø258 +0.5 -0	Ø290 +0.5 -0	Damper pocket
N	18 MIN	23.2 MIN	Clearance to crank bolts
H	Ø475 +0.1 -0	Ø475 +0.1 -0	Flywheel pilot
M	8.0 to 9.0	8.0 to 9.0	Chamfer 0.8 x 45° (Min) to Chamfer 1.5x30° (Max)
T	M10	M10	Fasteners x 12
F	Ø450	Ø450	Bolt circle
G*	66.5	66.5	FW Hsg to friction surface
E*	109.06	109.06	To rear of pilot brg
K*	19	19	Pilot Brg width recommended
L*	72	72	Pilot Brg OD recommended
P*	30	30	Pilot Brg ID required

Note: * marked dimensions are engine specific. The dimensions mentioned in the table above are for 6306 series bearings and ISO flywheel. Please refer to transmission installation drawing 5587300 for more details. Please contact customer support engineer for further information.

Pilot Bearing

Eaton Cummins Automated Transmissions Technologies, LLC requires high quality pilot bearings in accordance with SAE J1731 Standard-Duty Pilot Bearings procured from Original Equipment Manufacturers.

The maximum operating temperature of the pilot bearing in this system is 160°C. All components of the selected pilot bearing should be capable of withstanding temperatures up to the maximum operating temperature of the pilot bearing. The table below lists the requirements to follow when selecting a pilot bearing. Failure to comply with these requirements could result in early failure of the pilot bearing. Pilot bearing failure usually results in a warranty claim with symptoms of clutch drag, clutch noise, or input shaft pilot journal wear. In rare instances, pilot bearing failure may result in significant transmission damage.

Below is a list of the minimum recommended Pilot Bearing requirements:

Pilot Bearing Specifications	ECJV Requirements
Bearing Standard	SAE J1731: Pilot Bearings for Truck and Bus Applications, Standard-Duty Pilot Bearings (NTN part number 2TS2-6306LLUAC3/#04, 2TS2-6206LLUAC3/#02, 2TS2-5206LLUAC3#01 or equivalent)
Bearing Series	6306 or 6206 or 5206
Bearing Internal Clearance	C3*
Seal Material	ACM / Polyacrylic
Grease	Kyodo Yushi Multemp ET-KH (Synthetic Ether and Ester Base oil with Aromatic Diurea thickener)
Steel Elements	Temperature stabilized for 160 °C operation

Note: *SAE J1731 Specifies C5 clearance. However, C3 or greater is acceptable.

Compatibility and Operation with J1939 Communication

Endurant XD Series transmissions utilize SAE J1939 communications protocols on multiple CAN networks as the primary means of communication to other vehicle components. Endurant XD Series transmissions can support 250 Kbps or 500 Kbps networks and implement automatic baud rate detection if necessary. Other vehicle network types and protocols (i.e. J1587, LIN or FlexRay) are not supported.

Engine Idle Fueling Inhibit

 **WARNING:** This is a safety requirement. To protect against the loss of the ability to open the clutch and disengage the driveline, the vehicle system shall allow the transmission TCM to command the reduction or removal of engine idle torque in specific circumstances. Failure to allow the TCM to command the reduction or removal of engine idle torque in specific circumstances has the potential to result in unintended acceleration, unintended direction, unintended motion and increasing stopping distance due to the transmissions inability to disengage the driveline, which may result in serious injury or death.

 **WARNING:** This is a safety requirement. For scenarios where the TCM is not capable of disengaging the clutch and no longer in communication with the vehicle, the vehicle system shall have the means to detect loss of communication to an in gear transmission and to independently reduce or remove idle torque in appropriate circumstances. Failure to detect an unresponsive transmission that is in gear and reduce idle torque when appropriate has the potential to cause unintended vehicle acceleration and unintended vehicle motion or to increase vehicle stopping distance due to inability to disengage the driveline, which may result in serious injury or death.

Endurant XD Series transmissions are designed to utilize the Transmission Idle Governor Fueling Inhibit signals that are part of the J1939 ESR and EC2 message structure in the rare event the transmission is unable to disengage the driveline. Endurant XD Series-compatible engines are required to support these messages. Implementation is guided by the February 2016, SAE J1939 Digital Annex Figure SPN2432_A.

Driver Interface Device



WARNING: This is a safety requirement. The state of the driver interface device shall be communicated by dual outputs to improve robustness to single point errors in communication to the transmission. Failure to mitigate the single point failure of the driver interface device has the potential to result in unintended vehicle direction, unintended motion or reduced ability to move the vehicle from adverse conditions, which may result in serious injury or death.

The Endurant XD Series TCM can communicate with a driver interface device over one of two architectures, a dual CAN bus interface or a single CAN bus network with a PWM signal.

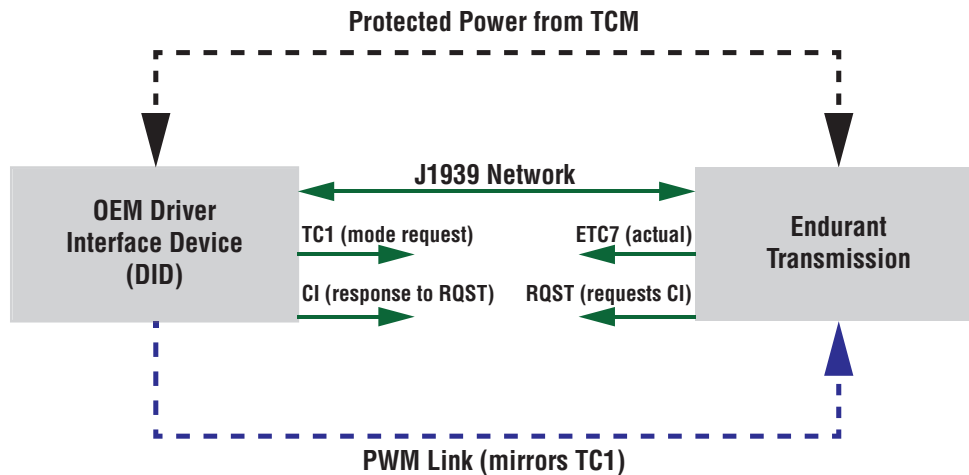

WARNING: This is a safety requirement. In order to not confuse a vehicle driver or conflict with the gear display during a mode transition, for driver interface devices equipped with illuminated mode indicators, the interface shall flash the requested mode indicator (and hold previous mode solid) if the mode feedback from the J1939 ETC7 message does not match the requested mode. Failure to communicate a mode change and agree with a vehicle driver display on driver interface devices equipped with illuminated mode indicators has the potential to cause unintended vehicle direction and unintended vehicle motion, which may result in serious injury or death.



WARNING: This is a safety requirement. To prevent miss-informing the vehicle driver, for driver interface devices equipped with illuminated mode indicators, the driver interface device shall show an error state or warning light within 500ms if the vehicle stops receiving valid J1939 ETC7 messages from the TCM. Failure to notify the driver of lost communication with the transmission has the potential to cause unintended vehicle direction and unintended vehicle motion, which may result in serious injury or death.

A typical driver interface device (DID) allows driver selection of “RNDML” (reverse, neutral, drive, manual, and low modes). All driver inputs are treated as requests and honored as dictated by vehicle operating conditions to ensure safe operation. Confirmation of the Transmission Requested Gear Feedback signal is found in the J1939 ETC7 message.

Please see “Section 7: Electrical System Requirements” on page 29 for details on DID electrical and communications interfaces to the transmission system.

- Driver Interface Device Modes:
 - Reverse Mode: Will initiate a sequence that puts the transmission in gearbox Reverse. The TCM will automatically select, engage, and shift to the appropriate Reverse gear to the engine/road speed conditions and vehicle configuration.
 - Neutral Mode: Initiates a sequence that puts the transmission in gearbox Neutral where no torque is transferred through the transmission.
 - Drive (Forward) Mode: Will initiate a sequence of events that places the transmission in gearbox into Drive, the standard mode of transmission operation. The TCM will automatically select, engage, and shift to the forward gear appropriate to the engine/road speed conditions and vehicle configuration.
 - Manual (Forward) Mode: Initiates a sequence that puts the transmission in gearbox Manual. The transmission engages a forward gear, but inhibits the automatic shifting. Shifts in Manual mode are accomplished by sending the appropriate UP or DOWN shift request. Shifts are allowed if the conditions satisfy vehicle limit criteria. Both single gear step and skip shifts are allowed.
 - Low (Forward) Mode: Initiates a sequence that puts the transmission in gearbox Low. The transmission engages a forward gear then executes a downshifting sequence with higher downshift points.

Note: Manual gear shift requests are allowed when the transmission is in Manual, Drive, or Reverse mode. The driver initiates a gear shift by requesting a gear Upshift or Downshift. The manually requested shift is allowed if vehicle conditions satisfy the shift criteria for the current gearbox mode.

Gear Display



WARNING: This is a safety requirement. To inform the vehicle driver of the transmission state, the vehicle driver display system shall provide a minimum of 2 digits to show transmission mode and status information conveyed via the Transmission Current Range (J1939 ETC2 message) signal. Failure to notify the driver and provide feedback information on the state of the transmission has the potential to cause unintended vehicle direction, unintended vehicle motion or other hazards associated with an uninformed driver, which may result in serious injury or death.



WARNING: This is a safety requirement. To prevent miss-informing the vehicle driver, the vehicle driver display system shall show an error state or warning light within 500ms if the vehicle stops receiving valid ETC2 messages from the TCM. Failure to notify the driver of lost communication with the transmission has the potential to cause unintended vehicle direction, unintended vehicle motion or other hazards associated with a misled driver, which may result in serious injury or death.

A gear display is required for proper transmission operation. The OEM is responsible for supplying the gear display and wiring per governmental safety standards, such as the Federal Motor Vehicle Safety Standard (FMVSS)

The gear display offers real-time information pertaining to current engaged gear, engagement status during gear shifting, transmission synchronization during shifting and transmission fault status. The gear display interfaces with the transmission with the J1939 ETC2 message. Two characters messages can also be displayed through the gear display as a means to communicate transmission information to the driver (i.e. "CA" for Clutch Abuse). Messaging content can vary by OEM, please contact VSI for specific details.

Alert Tone

 **WARNING:** This is a safety requirement. This is a safety requirement. To complement the visible warnings of the driver display system the vehicle system shall have an Audio Warning capability to communicate warning status to the driver including those communicated from the TCM. Failure to additionally notify the driver by audible means increases the likelihood a hazardous condition, if encountered, could go unnoticed by the driver, which may result in serious injury or death.

Required tone information shall be conveyed from the Endurant XD Series transmissions via the control character of the Transmission Current Range signal in the SAE J1939 ETC2 message. It is the OEM's responsibility to choose tone attributes (i.e. type, duration, frequency) for a given set of conditions. OEM's also have the ability to add audible notifications in addition to those explicitly sent from the transmission by triggering off other sources such as the Message Display, Gear Display and Driver Interface Device.

Service Lamps

Red and Amber transmission indicator lamps are required on the dash. The lamps shall respond to transmission broadcast J1939 DM1 messages. An Amber Lamp signal from the transmission would indicate the need for service while a Red Lamp signal would indicate the immediate need to cease driving and/or that vehicle motion is prohibited.

Accelerator Pedal

 **WARNING:** This is a safety requirement. The accelerator pedal system is the primary driver input for vehicle acceleration, the accelerator pedal shall confirm pedal movement by a minimum of two independent methods before the vehicle system transmits non-zero Accelerator Pedal Position (SPN91) or Driver's Demand Engine-Percent Torque (SPN512) values to the transmission. Failure to provide an input that does not accurately represent the vehicle drivers intent has the potential to cause the transmission to engage the driveline resulting in unintended vehicle motion, which may result in serious injury or death.

Hill Start Aid (HSA) and Anti-lock Braking System (ABS)

 **WARNING:** This is a safety requirement. The vehicle system shall provide accurate entry and exit information of ABS (skid) events to the transmission via a J1939 EBC1 Message signal. Failure to notify the transmission of skid events creates potential for reduction in lateral control of the vehicle due to loss of power steering (engine stalling) or abrupt driveline retardation, which may result in serious injury or death.

The OEM is required to install a hill start aid system in the vehicle. This often includes the addition of brake system valves and unique ABS controllers required by the brake manufacturer. The hill start aid system prevents unwanted vehicle movement on steep grades when transitioning from the brake pedal to the accelerator pedal. When hill start aid is activated, the system applies the foundation brakes for up to 3 seconds during operator brake-to-throttle transitions while the vehicle is operating forward or reverse, in either a 1% or greater grade (either incline or decline).

The hill start aid requires an operator accessible on/off override momentary control switch. The OEM is responsible for supplying the on/off control switch. The override switch is part of the brake system. Contact the brake controller manufacturer for hill start aid system and switch requirements.

The OEM is also responsible for providing a lamp to communicate system status messages of the "hill hold" switch. It is recommended that the light be amber in color and illuminate when the system is disabled or faulted.

Auto Neutral

An auto neutral feature is provided with this transmission which forces the transmission into neutral in all instances when the parking brake is applied. The Endurant XD Series system requires the use of the Park Brake Switch signal in the J1939 CCVS1 message to enable function of the Auto Neutral feature.

Front Axle Speed



WARNING: This is a safety requirement. To diagnose in-range transmission speed sensor failures and detect abnormal driveline accelerations (i.e. skid, slip) the vehicle system shall provide the transmission the Front Axle Speed (J1939 EBC2 Message) signal from an unpowered front axle. Failure to provide the transmission an accurate Front Axle Speed (J1939 EBC2 Message) signal has the potential to cause reduction in lateral control of the vehicle due to loss of power steering (engine stalling) or abrupt driveline retardation, which may result in serious injury or death.

The Endurant XD Series transmission also requires relative front wheel speed signals from the J1939 EBC2 Message for turning detection.

NOTICE: The current implementation of front axle speeds assumes an unpowered front axle. At this time Endurant XD Series is not approved for use with all-wheel drive powertrain configurations and/or powered front axles.

Parking Brake



WARNING: This is a safety requirement. The Park Brake Switch (J1939 CCVS1 message) signal will allow the Urge-to-Move feature when received as “off” by the TCM (and service breaks have already been released) to launch the vehicle. As such the vehicle system shall diagnose the Park Brake Switch (J1939 CCVS1 message) signal to protect against in range failures. The vehicle system shall also update the state of the Park Brake Switch (J1939 CCVS1 message) signal within 1 second of the driver pressing or releasing the park brake. Failure to provide an accurate Park Brake Switch (J1939 CCVS1 message) signal in a timely manner has the potential to cause the transmission to engage the driveline resulting in unintended vehicle motion, which may result in serious injury or death.

Optional Feature Integration:

Transmission Oil Temperature

The Endurant XD Series Transmissions are designed with internal oil temperature sensor to monitor the oil temperature during operation. The Oil temperature signal is broadcast over J1939 through TRF1 message by the TCM, which can be used by the OEMs to provide transmission oil temperature information to the driver.

Clutch Temperature

The Endurant XD Series Transmissions estimate the current clutch temperature and are broadcast over J1939 through ETC14 message. This signal is also used internally by the TCM for diagnostics and to set driver notifications of the transmission. There is an additional Clutch overheat indicator message broadcast over J1939 through ETC14 message. These messages can be used by OEMs to provide the clutch temperature or the clutch overheat state to the driver.

Using Rear Supports

The Endurant XD Series are designed to accept 8-bolt PTO and rear 4-bolt PTO and associated pumps without the need for a rear support. However, the OEM is responsible for determining if rear supports are needed. If rear supports are desired, the OEM is responsible for rear mount design. Refer to OEM for rear mount fastener torque specifications.

When a transmission rear support is utilized, the maximum spring support reaction force shall not exceed 2,670 Newton.

Configuration Parameters

In addition to the required calibration file previously described, the Endurant XD Series transmission also has optional configuration parameters which can be controlled independent of the calibration file. Configuration parameters are features, functions, and options that can be selected, enabled, disabled, or modified with discrete values by authorized internal or external parties. For production vehicles the default configuration parameters can be changed by the OEM Vehicle Equipment Programming Station (see VEPS section), in-service vehicles can have the configuration parameters changed with the ServiceRanger service tool provided the user has the correct permission level for a particular parameter.

Message Display

Endurant XD Series transmissions are capable of enhanced communication beyond the gear display through a variety of J1939 communication signals. Specific combinations of J1939 communications from the transmission can be used as triggers to display readable text by an appropriate dash display as desired by the vehicle OEM. For suggested text, available triggers and new triggers please contact VSI.

Cruise Control and Advanced Cruise Control Systems

The Endurant XD Series system uses J1939 information provided by the cruise control and advanced cruise control systems (Adaptive Cruise Control and Predictive Cruise Control), if present and configured properly, for certain features and functions. For further information on this feature please contact VSI.

Stability and Traction Control Systems



WARNING: This is a safety requirement. For vehicles equipped with optional stability (ASR) and traction control (ATC) systems, the vehicle system shall provide accurate entry and exit information of wheel slip events and system activation to the transmission via a J1939 EBC1 Message signal. Failure to notify the transmission of such events creates potential for reduction in lateral control of the vehicle due to loss of power steering (engine stalling) or abrupt driveline retardation, which may result in serious injury or death.

The Endurant XD Series system is capable of inhibiting shifts during many vehicle dynamic situations from information provided by vehicle systems over the J1939 network. Anti-slip and stability control events will all inhibit shifting in the transmission when the corresponding J1939 EBC1 Messages are received. The transmission system also has secondary independent detection capability for skid and slip events in the driveline.

Neutral Coast

The Endurant XD Series system has the ability to disengage the driveline to reduce parasitic losses of the powertrain and use the momentum of the vehicle to maintain speed for improved fuel economy under certain drive cycles. This feature can be set up to either use the transmissions internal coast decision logic or to accept a J1939 disengagement request from other vehicle systems (i.e. the engine). For further information on this feature please contact VSI.

Urge-to-Move and Service Brakes

The transmission system can provide an optional Urge-to-Move feature that will automatically provide a low level of torque transfer through the clutch once the brake pedal has been released. Torque transfer will continue to increase fully locking the clutch and then enter Creep Mode at engine idle speed.



WARNING: This is a safety requirement. For use of optional advanced transmission functions such as Urge-to-Move and Creep Mode, additional brake system information and sensing is required beyond the basic Brake Switch (J1939 CCVS1 message) signal. Brake Application Pressure (J1939 B message) or Brake Pedal Position (J1939 EBC1 message) are often one of the additional signals required and are sourced from independent sensors other than that used by the Brake Switch (J1939 CCVS1 message) signal. Specific requirements are dependent on the brake system architecture, availability of other signals and signal transmission rates. Failure to properly mitigate a single point failure of the service brake sensor and Brake Switch (J1939 CCVS1 message) signal has the potential to result in unintended motion, unintended acceleration and increased stopping distance of the vehicle due to the transmissions engagement/disengagement the driveline, which may result in serious injury or death.

Redundant J1939 Communication (CAN B)

The Endurant XD Series transmission system will experience several debilitating symptoms with the loss of primary J1939 communication. The OEM has the option to design redundant J1939 communication to the transmission to reduce these affects if so desired. The level of remaining functionality of the automated transmission system, depending on the level of integration of secondary J1939 communication, is as follows:

- No secondary Network: Fail in place with no functionality.
- Secondary Network, “Listen Only”: Launch permitted but limited to start gear, no shifting.
- Second Network, fully redundant: Driving and shifting permitted, loss of some functions.

The Endurant XD Series TCM continually broadcasts the Transmission Communications Failure Idle Torque Limit signal in the J1939 TCFG2 message as last instructions should the engine-to-transmission communication be lost.

Specific functionality will be dependent on the J1939 messages supported by the secondary network.

Power Take-Off (PTO) over J1939

In addition to the PTO hardwire options outlined in “Section 10: PTO Inputs and Configurations” on page 44, the Endurant XD Series transmission is capable of interfacing with transmission mounted PTO devices though other vehicle ECUs such as a cab or body controller. 8-bolt countershaft (PTO 1) and rear-mount through shaft (PTO 2) hand shaking is communicated through the J1939 PTO message. Implementation is guided by the SAE J1939 Digital Annex Figure PGN64932_B.

Auxiliary Transmission Integration

Endurant XD Pro can be integrated with a 2 speed AT-1202 auxiliary transmission through Hard-wire connections using configurable I/O or over J1939 CAN network. Endurant XD Pro will require one input for direct/low states of AT-1202. Please refer to TRTS0960, TRIG2620, or contact Customer Support Engineer for information on how to program the TCM to connect the Auxiliary Transmission over hard-wire connection or over J1939.

2-Speed Axle Integration

Endurant XD Pro can be integrated with 2 speed axle through Hard-wire connections using Configurable I/O or over J1939 CAN network. Endurant XD Pro will require one input for high/low state of the axle. Endurant XD Pro will learn gear ratios for both the states. Please refer to TRTS0960, TRIG2620, or contact Customer Support Engineer for information on how to program the TCM to connect the 2-speed axle over hard-wire connection or over J1939.

Rock-Free

The Endurant XD Pro Transmission can be configured with an optional Rock-Free Mode that can help the vehicle to initiate and maintain a back and forth motion to get out of a divot or a ditch. Please refer to TRTS0960, TRIG2620, or contact Customer Support Engineer for information on how to program the TCM with this feature to use hard-wire connection or over J1939 CAN Network.

NOTICE: The feature is only setup to accept an input from the momentary-on switch when the vehicle is setup with a hardwired input and output. Use of any other type of switch will trigger a fault rendering feature inactive.

Secondary Configuration Mode

The Endurant XD Pro Transmission can be configured with an optional Secondary Configuration Mode where the driver can change the system behavior affecting shift strategy, launch or maneuvering characteristics, ON/OFF road behavior and other transmission functions. Please refer to TRTS0960, TRIG2620, or contact Customer Support Engineer for information on how to program the TCM with this feature to use hard-wire connection or over J1939 CAN Network.

NOTICE: The feature is only setup to accept an input from the momentary-on switch when the vehicle is setup with a hardwired input and output. Use of any other type of switch will trigger a fault rendering feature inactive.

Reverse Output Signal

- The Endurant XD Series transmission TCM is configurable to provide an output to indicate when the transmission is in a reverse gear. Selection of REVERSE from a driver interface device will signal the TCM to enable the reverse out functionality. Please refer to TRTS0960, TRIG2620, or contact Customer Support Engineer for information on how to program the TCM with this feature to use hard-wire connection or over J1939 CAN Network.
- Reverse Out circuit line shall be able to withstand 0.14 amps for a 12-volt system (B-1 and B-5).
- An 18 AWG TXL cable is required at the TCM 20-way connector for sealing purposes.

Neutral (Range) Output Signal

The Endurant XD Series transmission TCM is configurable to provide an output to indicate when the transmission is in a specific gear range. The default configuration is to provide an output when in a neutral gear. Selection of NEUTRAL from a driver interface device will signal the TCM to enable the neutral output. Please refer to TRTS0960, TRIG2620, or contact Customer Support Engineer for information on how to program the TCM with this feature to use hard-wire connection or over J1939 CAN Network.

- Neutral Out circuit line shall be able to withstand 0.14 amps for a 12-volt system (B-3 and B-5).
- An 18 AWG TXL cable is required at the TCM 20-way connector for sealing purposes.

Force/Hold Neutral

Endurant XD Pro Transmissions can be equipped with Force/hold neutral feature which is activated by a switch input triggered by external devices such as a crane boom/outrigger arm. The transmission can be programmed to use either Force neutral or Hold neutral feature through ACN settings. Please refer to TRIG2620 or contact customer support engineer for information on how to program the TCM with this feature over hard-wired connection or over J1939.

Force Neutral: The transmission is forced into neutral mode and held on as long as the switch input is active. Pre-selection of neutral mode is not mandatory for this feature to function. The transmission shall deny selection of a non-neutral mode (Drive/Reverse/Manual/Low) when the feature is triggered correctly, and the switch input is active.

Hold Neutral: A pre-selected neutral mode is held on as long as the switch input is active. The Pre-selection of neutral mode is mandatory for this feature to function. The transmission shall deny selection of a non-neutral mode (Drive/Reverse/Manual/Low) when the feature is triggered correctly, and the switch input is active.

Oil Cooler Provision and Performance Requirements

The Endurant XD Series has two factory options:

- Case plugs (field upgradeable to cooler cartridges)
- Cooler cartridges with bypass valve and fittings

Note: Transmission side fittings are male JIC 37° flare, size: -10.

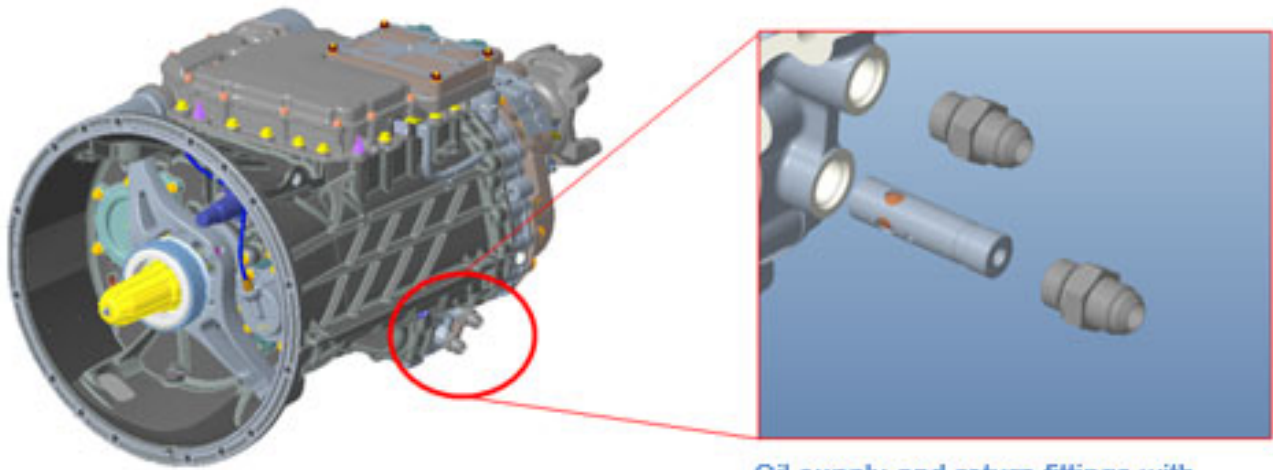

Oil supply and return fittings with integrated oil bypass cartridge.

Section 4

When a transmission oil cooler system is required, the below information should be used by OEMs to specify a cooling system:

Total Available Pressure Differential Total pressure differential available between the transmission cooler ports to persuade oil to flow through transmission oil cooler circuit.	0.55 bar [~8psi]
Maximum Transmission Exit Oil Temperature Maximum transmission exit temperature to be used for transmission oil cooler circuit design.	121°C [249.8 °F]
Transmission Oil Properties at 121 °C [~250 °F] PS-386	Density = 802 kg/m ³ Kinematic Viscosity = 9.7 cSt Heat Capacity = 2.141 J/(g °C)
Oil-to-Water Heat Rejection Engine Speed = 1500 RPM ETD = 16.7°C (Entering Temperature Difference) 104.3°C water temp	4.55kW
Air-to-Oil Heat Rejection Engine Speed = 1500 RPM ETD = 75°C (Entering Temperature Difference) 46°C Ambient OEM must ensure adequate air velocity over the oil cooler to meet minimum heat rejection. If the transmission oil cooler placement and/or radiator fan is insufficient to meet the heat rejection requirements, an auxiliary fan may be required.	Radiator Fan Off: 6.7kW @ 55mph 5.17kW @ 25mph 4.05kW @ 12mph 2.82kW @ 4mph Radiator Fan On: 4.55kW
Maximum System Pressure Peak pressure, under cold start conditions at -40°C.	10 bar [~145psi]
Unrestricted Flow Rate For reference only Flow rate for unrestricted flow of oil leaving the oil cooler supply port at 1500 rpm engine speed and 121°C oil temperature. Actual oil cooler circuit flow rate will be lower and will be determined by the provided total available pressure differential and restrictions from OEM oil lines, fittings, and cooler.	33L/min

NOTICE: As with legacy transmissions, the Endurant XD Series internals are not compatible with glycol coolant (engine coolant), significant glycol contamination will result in transmission damage. If oil-to-water coolers are to be used their design should minimize the possibility of coolant contamination into the transmission oil system.

Note: When an air-to-oil transmission cooler is used, stationary PTO power requirements should be considered when specifying cooler fans to ensure adequate air flow and heat rejection is achieved when the vehicle is stationary. Overheating of Transmission oil might result in damage.

Note: A transmission cooling system used on an Eaton heavy-duty manual or UltraShift PLUS transmission will be adequate to support a Endurant XD Series.

Section 5: Lubrication Requirements

NOTICE: The transmission lubricant shall be approved per Eaton PS-386 requirements as documented in the Lubrication Manual TCMT0021.

A list of approved lubricants and suppliers can be found in the Approved Lubricant Supplier Manual, TCMT0020. Not using the required lubricant will result in degraded performance and shortened life of the product.

- Lubrication capacity: 12 liters (Without PTO and without Oil Cooler)
- Additives and / or friction modifiers are not approved. Additives of any kind will result in unpredictable consequences. No liability of any kind will be accepted for any damage resulting from the use of such additives.
- Failure to use the required lubricant will affect the transmission performance and the warranty coverage.
- All approved lubricants are required to display the PS-386 approved logo.



External Oil Filter

External oil filters are not approved to be used with Endurant XD Series Transmissions.

In place of an oil filtration system Eaton Cummins Automated Transmission Technologies recommends care to be taken during the assembly of external oil lines and cooler systems to ensure contamination is not introduced into the transmission lubrication system.

Section 6: Pneumatic System Requirements

Supply Pressure



WARNING: This is a safety requirement. To maintain transmission functionality, the vehicle system shall have the air compressor OFF set no higher than 130psig (9.0bar). Failure to limit transmission air supply pressure below 130psig (9.0bar) has the potential to increase vehicle stopping distance due to the transmissions inability to disengage the driveline, which may result in serious injury or death.



WARNING: This is a safety requirement. To prevent transmission damage the vehicle system shall have a pressure relief valve in the supply system set no higher than 150psig (10.3bar). Failure to limit transmission air supply pressure below 150psig (10.3bar) has the potential to increase vehicle stopping distance due to the transmissions inability to disengage the driveline, which may result in serious injury or death.

For optimal performance, the Endurant XD Series transmission requires a nominal air supply operating range between 99 psi (6.8 bar) and 130 psi (9.0 bar). Air supply outside this range can result in degraded or complete loss of transmission shift capabilities. The following figure summarizes the significant thresholds for various air supply pressures.

NOTICE: Actions taken by the Endurant XD Series transmission in response to air supply pressures are not symmetrical and vary depending on if air supply pressure is increasing or decreasing such as transmission functionality allowed above 90 psi (5.9 bar) but not degraded until below 80 psi (5.5 bar).

Pressure Range Description	Bar	Ref. PSI	Response
Transmission Function Permitted	5.9	90	System Low Air Warning turns off. Gear engagement permitted.
Lower Operating Range	6.8	99	
Upper Operating Range	9.0	130	
Transmission Low Air Notification	5.5	80	(SPN-37 FMI-18): Transmission low pressure warning turns ON. Transmission remains functional at degraded performance (e.g. Non-N modes prohibited and upshifts not allowed; downshifts will continue).
Transmission Low Air Warning	5.2	75	(SPN-37 FMI-1): Transmission low pressure warning continues, system will then attempt to disengage driveline when or if it becomes appropriate.

Air Consumption

The table below shows the worst-case air consumption. Actual air consumption is a function of the transmission control algorithms and will be less in normal operation. These totals assume open clutch shifting for each shift.

Endurant XD Series Air Consumption Study		
	Gear Change	Air Consumption (L @ bar)
Drive	N-1	0.67
	N-2	0.67
	N-3	0.67
	N-4	0.67
	N-5	0.67
	N-6	0.67
	1-2	0.74
	2-3	0.67
	3-4	0.59
	4-5	0.72
	5-6	0.63
	6-7	0.56
	7-8	0.70
	8-9	0.71
	9-10	0.76
	10-11	0.73
	11-12	0.66
	12-13	0.58
13-14	0.61	
14-15	0.54	
15-16	0.50	
16-17	0.61	
17-18	0.54	
Reverse	N-R1	0.67
	N-R2	0.67
	R1-R2	0.74
	R2-R3	0.72

Air Quality

The Endurant XD Series transmission air supply is required to meet or exceeded ISO 8573-1:2010 7.3.4. The vehicle air system supplying the transmission shall use a high quality commercially available oil coalescing air dryer. Air quality for solid contamination shall meet a minimum of ISO 8573 Class 7. Air quality for water contamination shall meet a minimum of ISO8573-1 Class 3. Air quality for oil contamination shall meet a minimum of ISO 8573-1 Class 4.

Limits of relative humidity of the supplied air must be below the values listed below. The dew point reduction of the air supply system shall meet a minimum of ISO 8573 Class3.

Ambient Temperature °C (°F)	-40 (-40)	-20 (-4)	0 (32)	20 (68)	40 (104)	60 (140)	80 (176)
Relative Humidity %	8.5	12.5	17.0	25.0	32.0	37.0	42.0

NOTICE: Air additives such as alcohol devices should not be permitted to enter the transmission air supply. Additives could cause damage to air system components, which could lead to degraded transmission performance.

Air Supply Requirements



WARNING: Loss of pneumatic integrity of the transmission air supply line (blow off) may result in rapid loss of transmission air supply pressure without warning. Vehicle OEMs shall select appropriate hose, fittings and routing for the vehicle application and ensure proper assembly in vehicle. Failure to design and properly install an adequate transmission air supply system may increase the chance of rapid loss of air supply pressure without warning having potential to cause unintended motion, increased vehicle stopping distance or reduced ability to move the vehicle from adverse conditions, which may result in serious injury or death.

Air Supply



WARNING: This is a safety requirement. To ensure that the air pressure sensed by the transmission represents a usable volume of air and to isolate the transmission air supply from other vehicle air systems, the transmission air supply shall have unrestricted access to a dedicated air volume of at least 10-liters and be isolated from upstream air supply by a check valve. Failure to provide the transmission with unrestricted access to a usable volume of air and isolate it from other vehicle air systems has the potential to increase vehicle stopping distance or reduced ability to move the vehicle from adverse conditions, which may result in serious injury or death.

- Clean, dry air is required for the transmission system to shift properly.
- If desired, OEMs may choose to install a Pressure Protection Valve (PPV) in-line with the required check valve.

Port

- The mechatronic transmission module (MTM) has an ISO 6149-1 metric straight thread o-ring port for the air line connection. The port size is an M18x1.5, with metric ISO 261 metric thread.

Fitting

- It is recommended that an O-ring fitting that mates to the ISO 6149-1 M18x1.5 port be used. O-ring material should be selected based on OEM experience with air systems. The operating temperature limit for all electrical and air system components is 221 °F (105 °C)

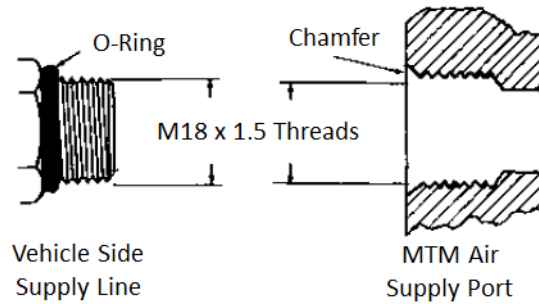

Hose

- The OEM shall select the air hose based upon government regulations and experience with vehicle air systems.
- The inside diameter of the air hose shall not be less than 10.9 mm.

Hose Routing

- Air lines should not be routed or attached at the bottom air tank fittings to avoid any chance of introducing moisture into the airline.
- Proper air hose routing techniques shall be followed with appropriate clipping points to eliminate any chaffing that may occur on the hose.
- OEM air supply hose shall not be routed and clipped to the pre-installed output shaft speed sensor harness.

Section 7: Electrical System Requirements

NOTICE: “Power” refers to both power positive and power negative supply. This is typically battery plus and battery negative. “Switched ignition” refers to power that is enabled with ignition key operation.

Power Requirements

- The vehicle primary power system shall be a 12-volt system.
- The OEM shall provide power to the TCM that does not exceed a steady state voltage of 16 volts DC.
- The vehicle shall have a negative ground power system.



WARNING: This is a safety requirement. To eliminate any single point failures that could incapacitate the TCM, particularly while the driveline is engaged, the vehicle system shall provide two independently fused power positive supply lines, each capable of sustaining the power requirements of the TCM. These lines shall be continuous between the TCM vehicle connector and a power source such that a single point failure does not disrupt power to the TCM. Failure to protect the TCM power supply lines from single point failure has the potential to cause:

- Unintended vehicle acceleration
- Unintended vehicle motion
- Increased stopping distance
- Physical harm related to service
- Serious injury or death
- The OEM shall provide two independent power negative supply lines, each capable of sustaining the power requirements. These lines shall be continuous between the TCM vehicle connector and a power source such that a single point failure does not disrupt power to the TCM.
- The OEM shall provide power wiring to the TCM such that the differential voltage (TCM negative subtracted from TCM positive, for each individual power line) shall exceed 9 VDC at a steady state load of 15 amps as configured for a 12-volt.
- The OEM shall provide switched ignition wiring to the TCM such that the differential voltage (TCM negative subtracted from TCM Switched Ignition input) shall exceed 9 VDC at a steady state load of 1 amp as configured for a 12-volt system.
- Power and switched ignition to the TCM shall not drop below 9 volts DC during the engine start process.
- Engine start interlock shall meet FMVSS 102 Section 3.1.3 standards: “The engine starter shall be inoperative when the transmission shift lever is in a non-neutral position”. See “typical start enable relay circuit” in this section.
 - Hardwired start enable relay circuits are not required if J1939 equivalent is available.
- If a disconnect switch is used for the engine control module (ECM), it shall be configured such that it also removes power to the transmission control module (TCM).

NOTICE: Removal of ignition power (pin V-10) quickly followed the removal of constant power (pins V-6 and V16) may not provided the TCM adequate time to power down and could result in loss of information.

Mating Connector and Terminal Requirements

- Connectors shall be designed for use in the heavy-duty industry, conforming to SAE-J2030 and SAE-J1455.
- Terminal position assurance (TPA) and connector position assurance (CPA) devices shall be used on connector systems that support those devices.
- When interfacing to Endurant XD Series components, use connector systems specified within Endurant XD Series documentation or an approved equivalent.
- Mating halves of terminal systems shall use plating materials that are compatible with each other.
- Terminal plating shall be gold for all TCM interfaces.
 - Recommended minimum plating thickness of 0.75 microns of gold over 1.2 micron of nickel.
- Required wire size:
 - The cable for the Delphi 20-way connector B (13976573) shall be 18 TXL for all wires.
 - The cable for the Delphi 20-way connector V (13885474) for Pins 5, 6, 15 and 16 shall be 16 TXL.
 - The cable for the Delphi 20-way connector V (13885474) for all Pins EXCEPT 5, 6, 15 and 16 shall be 18 TXL.

NOTICE: Specified cable sizes ensure proper connector sealing and current carrying capacity.

NOTICE: Cable cross-sectional area and insulation are specified to ensure proper connector cable sealing and current carrying capacity.

Electrical Sealing Requirements

- Separable connectors outside of the cab shall be sealed per SAE-J2030 standards.
- Unused connectors shall have sealed mating connectors or plugs.
- Unused terminal cavities shall have sealed mating connectors or plugs.
- Seals shall be selected based upon cable outer diameter and connector cavity specifications.

Network Communication Requirements

The use of either shielded or unshielded twisted pair shall be an OEM decision based upon EMC validation testing.

- Required controller area network (CAN) communication with the vehicle engine.
- The OEM is provided the option of supporting CAN communications utilizing the SAE J1939 CAN physical layer with shielded twisted pair data cable (SAE J1939/11) or unshielded twisted pair data cable (SAE J1939/15).
 - For shielded, twisted-pair installations (STP), the data link cable, connectors, and termination shall meet the performance and assembly requirements of SAE J1939/11.
 - For unshielded, twisted-pair installations (UTP), the data link cable, connectors, and termination shall meet the performance and assembly requirements of SAE J1939/15.
- Twisted pair requirements:
 - 2 Cables = 10 Twists / 25.4 cm
 - 3 Cables = 8 Twists / 25.4 cm
 - (16 and 18 Gauge Cable Only)

Vehicle Service Requirements for Electronics

- Battery positive and negative circuits to the Endurant XD Series TCM must be disconnected prior to any type of welding on the vehicle.
- Battery negative must be disconnected prior to removal or installation of TCM harness connectors.
- Removal and/or replacement of a battery shall not disturb the terminating connectors of the TCM.

OEM Interface Connections

- There will be two Delphi 20-way connectors that mate with the transmission control module.
- The Delphi 20-way vehicle connector (Delphi P/N 13885474 – index key V) is configured to receive 16 circuits utilizing 0.8 mm² (18 AWG) TXL wire and 4 circuits utilizing 1.0 mm² (16 AWG) TXL wire. The four 1.0 mm² (16 AWG) circuits are for the TCM power and ground circuits. These circuits are located in cavities 5, 6, 15 and 16 of the vehicle connector. The vehicle connector is dark gray in color. See the respective charts below for more detail.
- The Delphi 20-way body connector (Delphi P/N 13976573 – index key B) is configured to receive 20 circuits that utilize 0.8 mm² (18 AWG) TXL wire. The body connector is light gray in color. See the respective charts below for more detail.
- The transmission will be delivered with two green environmental shipping caps (Delphi P/N 13885475) installed.
- A Connector Position Assurance (CPA) (Delphi P/N 15357145) shall be used to secure the fully engaged connector lever lock in the latched position.

NOTICE: All unused connector cavities shall be plugged to prevent water intrusion. Both connectors use the Delphi plug (Delphi P/N 15305171). Use as required.

20-Way Vehicle Connector

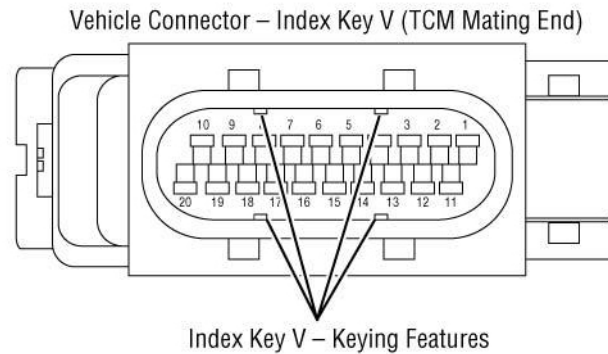

Vehicle Connector Pin No.	Wire AWG	Circuit Description
V-1	18	Plugged (not used)
V-2	18	Plugged (not used)
V-3	18	Plugged (not used)
V-4	18	Start Enable – Negative
V-5	16	Battery Negative 1*
V-6	16	Battery Positive 1*
V-7	18	Fluid Pressure Sensor – Signal
V-8	18	Protected Power Return
V-9	18	Driver Interface Device (Mode request from DID)
V-10	18	Ignition Wakeup (Input)
V-11	18	CAN A – High (Primary J1939)
V-12	18	CAN A – Low (Primary J1939)
V-13	18	CAN A – Shield (Primary J1939)
V-14	18	Start Enable – Positive
V-15	16	Battery Negative 2*
V-16	16	Battery Positive 2*
V-17	18	Protected Power (Output)
V-18	18	Fluid Pressure Sensor - Ground
V-19	18	Fluid Pressure Sensor - Power
V-20	18	Plugged (not used)

* Refers to “power requirements” identified at the beginning of Section 7

Suggested parts for TCM vehicle connector

Component	Delphi Part #	Quantity
Connector Body	13885474	1

Section 7

Terminal	15471370	20
Secondary Look	13885454	1
Connector Position Assurance (CPA)	15357145	1
Cab Seal	15305351	20
Back shell Cover	15476351	1

20-Way Body Connector

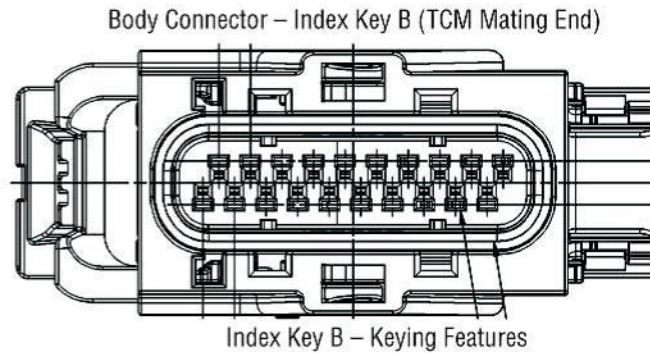

Body Connector Pin Number	Wire AWG	Circuit Description
B-1	18	Configurable Output 1
B-2	18	Configurable Output 2
B-3	18	Configurable Output 3
B-4	18	Configurable Input 2
B-5	18	Body I/O Return 1
B-6	18	Configurable Input 1
B-7	18	CAN B - High (Secondary J1939)
B-8	18	CAN B - Low (Secondary J1939)
B-9	18	Plugged (not used)
B-10	18	Plugged (not used)
B-11	18	Plugged (not used)
B-12	18	Plugged (not used)
B-13	18	Plugged (not used)
B-14	18	Body I/O Return 2
B-15	18	Configurable Input 3
B-16	18	Configurable Input 4
B-17	18	Plugged (not used)
B-18	18	Plugged (not used)
B-19	18	Plugged (not used)
B-20	18	Plugged (not used)

Suggested parts for TCM body connector

Component	Delphi Part #	Quantity
Connector Body	13976573	1
Terminal	15471370	20
Secondary Lock	15366676	1
Connector Position Assurance (CPA)	15357145	1
Cable Seal	15305351	20
Back shell Cover	15476351	1

Configurable I/O

Endurant XD Series transmissions have the ability to configure 7 body connector pins used for vocational interfaces in an effort to cover as many body builder integration options and global chassis variation as possible. There are 3 relay outputs and 4 digital inputs that are configurable. The vocational features that are desired to be configured through hard-wired configuration are combined into Configurable I/O Packages which can be programmed on the TCM.

Endurant XD Series TCM can be programmed with 4 configurable inputs and 3 configurable outputs to support the function of the following features through Hard-wired connection:

- PT01
- PT02
- 2 speed Aux Trans
- 2 Speed Axle
- Mode A/B Switch
- Rock Free Switch
- Reverse Output
- Range (Neutral) Output
- Force/Hold Neutral
- Split Shaft PTO

Note: Endurant XD Series can be configured to support PT01, Reverse Output, and Range (Neutral) Output. All other features are supported only on Endurant XD Pro.

Configuration procedure:

1. For configuring the truck with PT01/Reverse Output/Neutral Output through Hard-wired connection, please use ServiceRanger/VEPS tool to download appropriate Configurable I/O package. For details on several configurable I/O packages and relevant wiring schematics, please refer to TRIG2620.
2. For configuring any other feature, please contact Customer Support Engineer.

Fluid Pressure Sensor

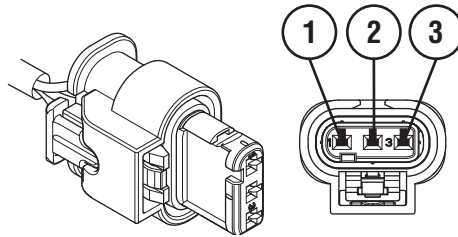

For transmissions equipped with the fluid pressure sensor, the OEM vehicle wiring harness is required to make the connection between the fluid pressure sensor and the TCM vehicle connector.

Vehicle Connector Pin No.	Wire AWG	Fluid Pressure Sensor Connector Pin No.	Circuit Description
V-7	18	3	Fluid Pressure - Signal
V-18	18	2	Fluid Pressure - Ground
V-19	18	1	Fluid Pressure - Power

Suggested parts for fluid pressure sensor harness

Component	TE AMP Part #	Quantity
MCON LL Housing	1-1718644-1 (125C) or 1-1718644-5 (150C)	1
Terminals	7-1452671-2	3
Cable Seal	967067-1	3

Driver Interface Device (DID)

The driver interface device system provided by the OEM shall meet the electrical system interface requirements found in section 3 of this document.

The TCM will control the power up and shutdown of the driver interface device as needed.

The vehicle OEM is responsible for making the appropriate electrical connections for the driver interface device to the TCM vehicle connector and supplying any required electrical connector for the driver interface device.

Typical communication is through the J1939 communications network (primary) and a PWM input. The driver interface device PWM signal is a nominal 100 Hz pulse width modulated 0-5 volt DC signal intended as a non-primary signal to communicate TC1 information. The maximum low state voltage shall be less than 0.250vdc and the minimum high state voltage shall be 4.750vdc. Under normal operation this signal will provide a mode confirmation signal according to the gear requested (see table below). The PWM signal shall be simultaneous to the TC1 message within 50 mS and is intended to be used as a comparative signal. The signal shall be pulse width modulated in such a way as to provide the following duty cycles for given gear requests.

Mode	Nominal PWM output of driver interface device (% Duty cycle)*	TC1 output (hex)
No mode selected	10	E0
R	60	DF
N	50	7D
D	40	FC
M	30	FD
L	20	FA
Internal Failure	Constant value of 2.5 volts DC (+/- 0.5 volts).	FE

The driver interface device shall be electrically compatible with a 12-volt vehicle electrical system. The driver interface device shall consume no more than 1.00 amp from transmission protected power. The driver interface device shall conform to the operating voltage requirements below.

NOTICE: The below table encompasses the use the DID on a 12 or 24 volt DC vehicle system. While the Endurant XD Series transmission is not currently 24-volt compatible the OEM may choose to design protect the DID for future 24-volt systems with the information in the table.

Voltage	Description	Operation
Above 36	Over Voltage	Power is not supplied to the Driver Interface Device.
32 to 36	Survival	The Driver Interface Device must not be damaged. The Driver Interface Device is not required to be functioning.
6 to 32	Normal Operating Range	Driver Interface Device will operate normally and meet all specifications. If voltage increases into this range from a power down condition, the Driver Interface Device is not required to power up until voltage is above 8.5 VDC
0 to 6	Power Down	The Driver Interface Device is expected to power up and shut down in an orderly fashion. Hysteresis is required between the power up and shut down thresholds. Degraded lamp and tone performance is acceptable.
-28 to 0	Reverse Voltage	The Driver Interface Device is expected to survive and operate after exposure to reverse voltage.

The driver interface device network shall have no failure modes that would induce an electrical hardware failure in the TCM, or any other transmission component connected to the driver interface device.

The TCM is designed to tolerate shorts to ground and high impedance failures in connected circuitry, but cannot tolerate high voltages or current surges.

The driver interface device network shall not impose any additional service or maintenance requirements on the TCM.

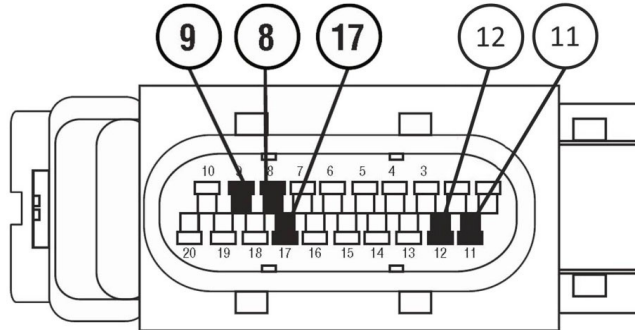

Connector V (TCM mating end)

From	To	Description
V-9	OEM	Mode Indicator (PWM)
V-8	OEM	Protected Power (return)
V-17	OEM	Protected Power (supply)
V-12	OEM	CAN A Low (Primary J1939)
V-11	OEM	CAN A High (Primary J1939)

Typical Start Enable Relay

- Engine start function is the responsibility of the OEM vehicle system.
- The OEM shall provide the circuit connecting TCM (V-14 and V-4) to the start enable relay.
- The start enable relay driver circuit is a high side and low side driver pair designed to provide a fault tolerant control of the starter enable circuit. The driver circuit is intended to provide a nominal 0.14 ampere for a 12-volt system relay coil.
- An engine starter interlock function that is active once the transmission determines that starter operation is allowed per United States Federal Register, 49 CFR Part 571, Federal Motor Vehicle Safety Standards (FMVSS); 571.102 Standard No. 102; Transmission Shift Position Sequence, Starter Interlock, and Transmission Braking Effect, Section S3.1.3: “Starter interlock. Except as provided in S3.1.3.1 through S3.1.3.3, the engine starter shall be inoperative when the transmission shift position is in a forward or reverse drive position.”
- The starter interlock function is provided through two mechanisms.
 - Engine starter interlock function using a control message communicated from the SAE J1939 CAN communication line. (J1939 start enable type - the J1939 ETC7 SPN 2900 transmission crank enable message may be used to enable cranking without a relay. This feature can be configured with VEPS or ServiceRanger).
 - Engine starter interlock function using a relay contact inserted in the engine started enable circuit path (engine start enable relay).
- The OEM shall be responsible for over-current protection of the switched ignition input on the switched contact side of the start enable relay.
- A representation of the minimum implementation of the start enable relay circuit for the Endurant XD Series transmission is shown below.

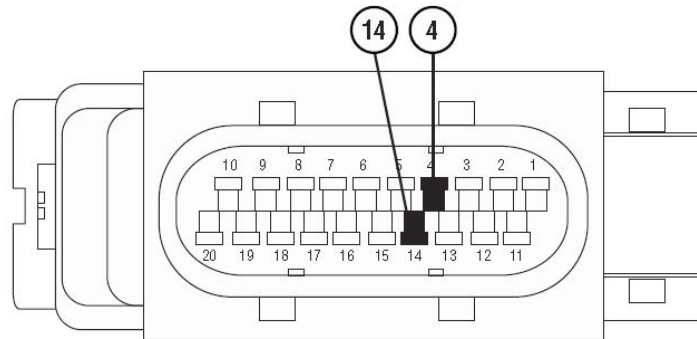

Connector V (TCM mating end)

From	To	Description
V-14	86	Start Enable Positive
V-4	85	Start Enable Negative

Control Area Network (CAN) Communications

- The CAN A data link shall be utilized for network communications between the TCM and other components on the vehicle, such as the engine control module (ECM). The CAN A data link is also known as the public J1939 data link.
- The CAN B data link is utilized as a redundant link with the engine ECM. The CAN B data link is only available on the 20-way body connector.
- Both the CAN A and CAN B data links shall conform to either SAE J-1939/11 or SAE J-1939/15.

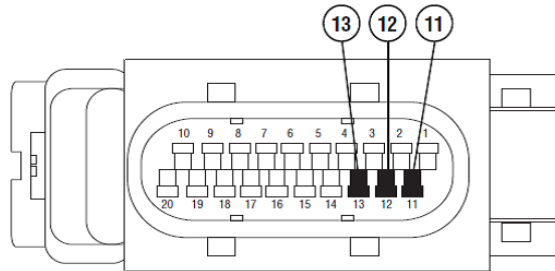

Connector V (TCM mating end)

From	To	Description
V-11	A	CAN A High (Primary J1939)
V-12	B	CAN A Low (Primary J1939)
V-13	C	CAN A Shield (Primary J1939)

Section 8: Electrical Wiring Recommendations

Electrical Contact Lubrication Recommendations

NyoGel® 760G is recommended on all electrical contacts that are not gold plated. The preferred method of application is to use a metered dispensing mechanism that places the material on the socket of the connector. It is also preferred that the material be placed immediately prior to connector mating to reduce the probability of contamination.

Harness Design Recommendations

- Splices shall be ultrasonically welded and encapsulated and sealed to meet SAE-J1455.
- Convoluted conduit shall have a service temperature of at least 257° F (125° C) and be made of a material that mitigates chafing of the wire insulation.
- Braided loom shall have a service temperature of at least 280° F (138° C). Coverage: A minimum of 10 picks per inch / maximum of 12 picks per inch.

Electrical Juncture Recommendations

- Do not use more than 3 ring terminals per mounting stud. Terminals such as ring, bullet, spade, etc., shall be sized for the correct current capacity of the circuit as stated by the manufacturer. Terminals shall be plated and non-insulated. Mated terminal plating shall be selected such that it prevents galvanic corrosion between contacting surfaces. Sleeves shall be insulated with a double wall shrink tubing. Sealing dielectric grease over the top of the ring is recommended.
- Do not use lock washers or star washers for contact surfaces.
- Terminal crimps and crimp tooling shall meet or exceed terminal manufacturer's specifications.

Section 9: Harness Routing and Clipping Requirements

- Harness and in-line connectors shall be anchored to prevent free movement. An anchor point shall be no further than 6 in [15.24 cm] (recommended 3 in [7.62 cm]) from a connector. The length of an unanchored section of harness should be no more than 12 in [30.48 cm].
- Multiple threaded bosses and mounting holes are provided on the transmission to which vehicle components can be clipped. The OEM shall not mount additional components to TCM, transmission brackets, mounting studs or lifting eyes under any circumstances without approval. This includes cap screws used to fasten any housing, bearing covers and PTO covers. Removal of these will compromise transmission system operation and overall system reliability.
- Tie wrap application and tightness shall conform to Section 14.1.1 of IPC/WHMA-A-620 “requirements and acceptance for cable and wire harness assemblies”, January 2002 revision or later. Tie wrap application shall meet the “target and defect” of a Class 3 product per IPC/WHMA-A-620. Use tie wraps on harness covering only, not individual wires. Do not anchor harness with tie wraps in contact with wire insulation. Tie wraps shall not pull on the harness such that connector cable seals are distorted. Cable anchors shall be installed in a manner that prevents cables from exerting excess strain on the connector body.
- The bend radius of a harness bundle shall be greater than 6 times the diameter of the harness bundle. Exceptions require Engineering approval.
- The bend radius of an individual cable shall be greater than 2.5 times the diameter of the individual cable. Exceptions require Engineering approval.
- Harness installation shall utilize fixed clip points, for example, Fir trees, J-clips and P-clips.
- Harness routing shall not interfere with user accessible points such as oil fill and oil drain locations, pneumatic fitting, PTO opening, lifting eyes, sensor locations, or applicable manufacturing fixture locations.
- The TCM mating end of the vehicle harness shall be divided into two distinct branches, one for each 20-way TCM connector.
- The TCM/vehicle interface harness (and optional body harness if used) shall be secured to the supplied clipping bracket located directly behind the TCM with plastic cable ties. The following view illustrates the harness routing and clipping points.

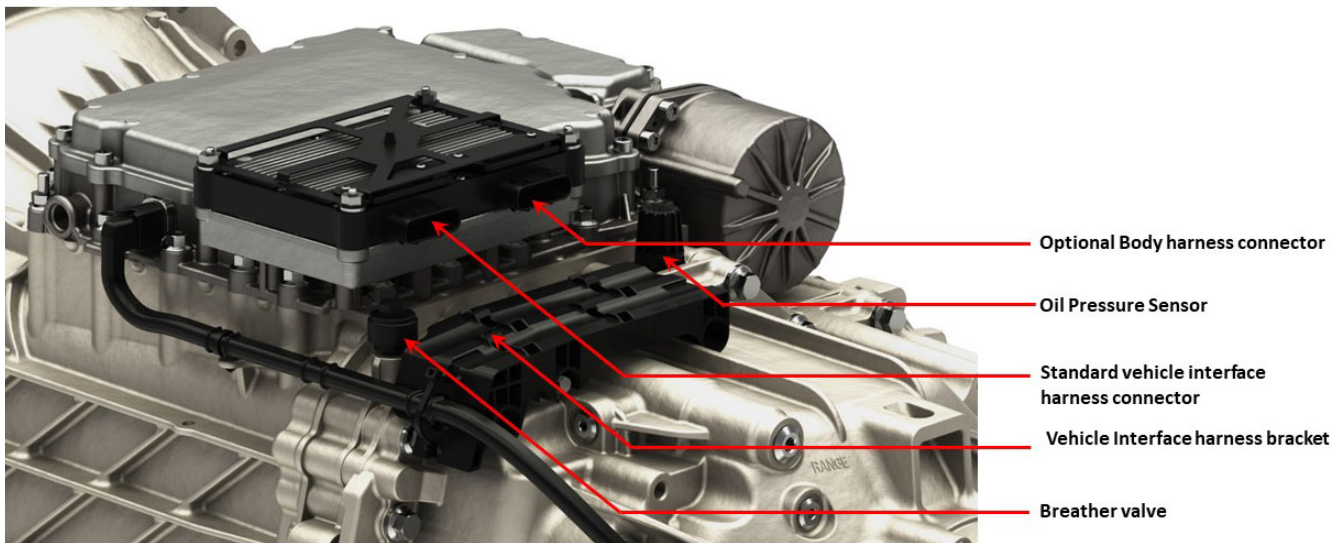

Predetermined Clipping Points

NOTICE: Ribs and gussets are not designed as attachment locations unless specifically supplied with that intended purpose. Rib and gusset attachment devices, such as “hammer clips” are not approved for use on Endurant XD Series transmissions.

NOTICE: The OEM design shall not allow for removal of any transmission cap screws from any gasketed joint for any reason within the OEM assembly plant. Removal of any cap screw from a gasketed joint introduces a high risk of creating a lubrication leak, reduced structural integrity, and can compromise transmission system operation and overall system reliability. This includes cap screws used to fasten the mechatronic transmission module (MTM), transmission control module (TCM), linear clutch actuator (LCA), rear bearing cover, PTO cover, main case to clutch housing fasteners, and rear case to main case fasteners.

NOTICE: Eaton has provided multiple provisions for clipping of OEM harnesses, hoses, cables, etc. The pre-installed transmission output speed sensor harness shall not to be used for securing additional OEM-installed content.

NOTICE: OEM harness routing shall not interfere with user accessible points such as oil fill and oil drain locations, pneumatic fitting, PTO opening, lifting eyes, sensor locations, or applicable manufacturing fixture locations.

Approved OEM clipping points for periphery equipment are:

- 3 Studs, M8x1.25, 13mm long on top
- 6 M10 through holes, 3 each side
- 3 Bottom Rear of Rear case Pre-tapped Support Bosses M10x1.5 22.5mm deep
- 2 Top Rear of Rear Case Rear Pre-tapped Support Bosses M12 X 1.75, 24-mm deep

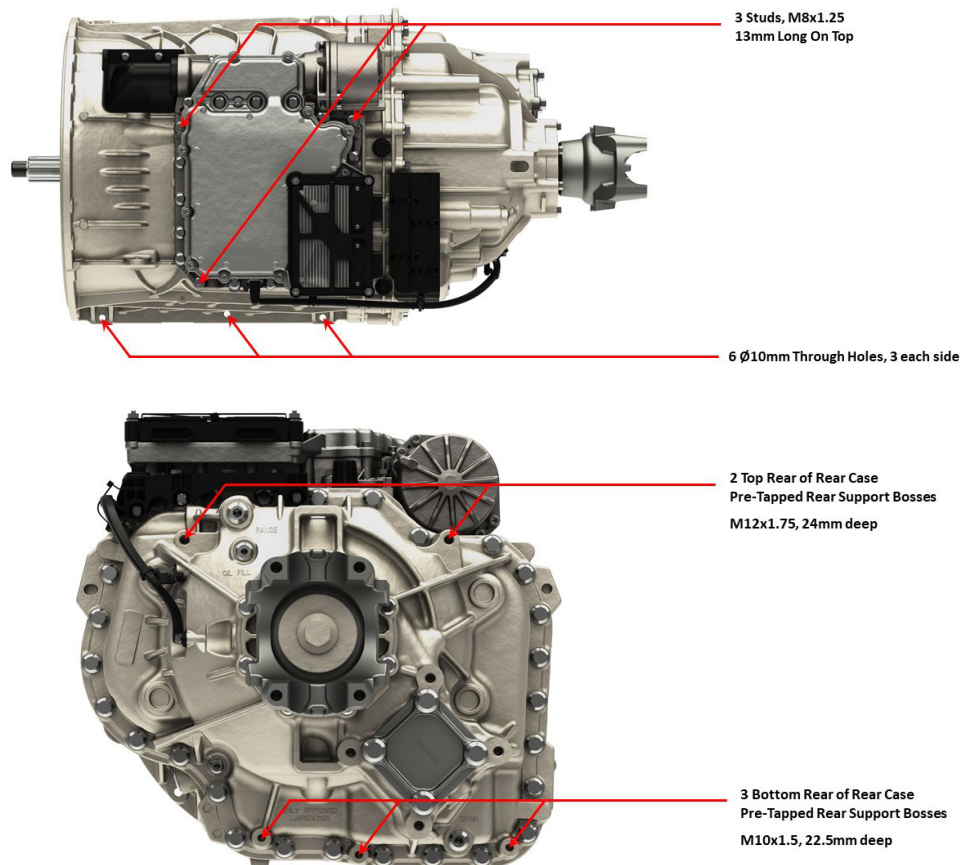

Section 10: PTO Inputs and Configurations

- The Endurant XD Series transmission is designed to provide an enhanced acknowledgment for PTO applications. The TCM will receive a “PTO request” from the vehicle to enter into a PTO mode. If the TCM deems that conditions are suitable for PTO operations, the TCM will supply a “PTO engage” output to allow the PTO engagement. A confirmation from the PTO returns to the TCM via the “PTO confirm” line to complete the loop. The TCM has the functionality to support two PTOs at the same time – one direct wire control and one over the J1939 network. Please refer to TRIG2620: Endurant XD Series PTO Installation Guide for further details.
- PTO operation requires a double pole single throw switch.
- Consult PTO manufacturer for power requirements needed for fuses, switches and wires on PTO circuitry.
- TCM request and confirmation circuit lines will provide 1 milliamp of current for a 12-volt systems.
- The TCM engage circuit load shall draw no more than 0.50 amps with 16 volts applied for a 12 volt vehicle system.
- An 18 AWG TXL cable is required at the TCM 20-way connector for sealing purposes.
- Implementation of the hardwired option is guided by the SAE J1939 Digital Annex Figure PGN64932_C. The TCM will also support PTO request via SAE J1939 protocol, see Section 5 System and Feature Integration.

Section 11: OEM Assembly Procedures

Suggested Installation and Diagnostic Tools

Installation and Assembly Tools

Description	Usage	Supplier	Item Number
Clutch Installation Alignment Shaft	Clutch installation	K-Line Special Service Tools	RR1064TR
Clutch installation alignment dowels	Clutch installation	Determined by OEM	Per supplier
3/8 in. flat-nose punch (brass preferred)	Set clutch control fingers	Determined by OEM	Per supplier
15 mm socket	Fasteners, clutch-to-flywheel	Determined by OEM	Per supplier
Quick-connect air fitting: M18 x 1.5	Transmission pull-to-neutral	Determined by OEM	Per supplier
6 mm internal hex key	Lubrication fill plug	Determined by OEM	Per supplier
8 mm internal hex key	Lubrication check plug	Determined by OEM	Per supplier
Lubrication dispensing nozzle to fit 16 mm hole	Lubrication fill	Determined by OEM	Per supplier
27 mm socket	Output yoke retainer screw	Determined by OEM	Per supplier
Pull-to-neutral box	To place transmission in neutral	K-Line Special Service Tools	500-455
Grade sensor calibration box	To calibrate grade sensor	K-Line Special Service Tools	500-453

Diagnostic Tools

Description	Supplier	Item Number
*Eaton ServiceRanger PC-based Diagnostic Tool	Eaton	None

Note: Regarding Eaton ServiceRanger: In many cases OEM information technology (IT) departments manage deployment of ServiceRanger and program updates to the OEM assembly plants. Where this is the case, Eaton recommends that all OEM assembly plants consult with their IT departments for program procurement and program update procedures. Installing ServiceRanger requires full administrator privileges. Installation information and other support for ServiceRanger can be obtained at: <http://www.roadranger.com/rr/CustomerSupport/Support/ServiceRanger/>

Component Packaging and Handling

Clutch Assembly

Clutch assemblies for Endurant XD Series transmissions systems are shipped to OEM assembly plants in molded plastic containers that are very similar to legacy Eaton heavy-duty clutch packaging. Maximum stacking height for containers holding four clutch assemblies is 3-containers high.

The OEM assembly plant should follow existing processes for returning the shipping containers to Eaton or to a contracted third-party sequencer.

NOTICE: The installer must avoid unnecessary rough handling of the clutch assembly during the product sequencing and assembly process to avoid unintended movement of the clutch assembly control fingers and potential shock to the pressure plate. Any accelerated impact to the clutch assembly, such as dropping the assembly face down, may cause the pressure plate to 'bounce' and allow the adjusting cam to rotate inside of the clutch assembly. Rotation of the adjusting cam results in an over-adjusted condition and will require a full bench reset of the clutch assembly.



NOTICE: Eaton recommends lifting the clutch using two clutch cover mounting holes when removing clutch assemblies from the shipping containers. Avoid using any lifting device in the clutch center opening to prevent handling damage to the clutch diaphragm spring. A suggested lifting device shown below.

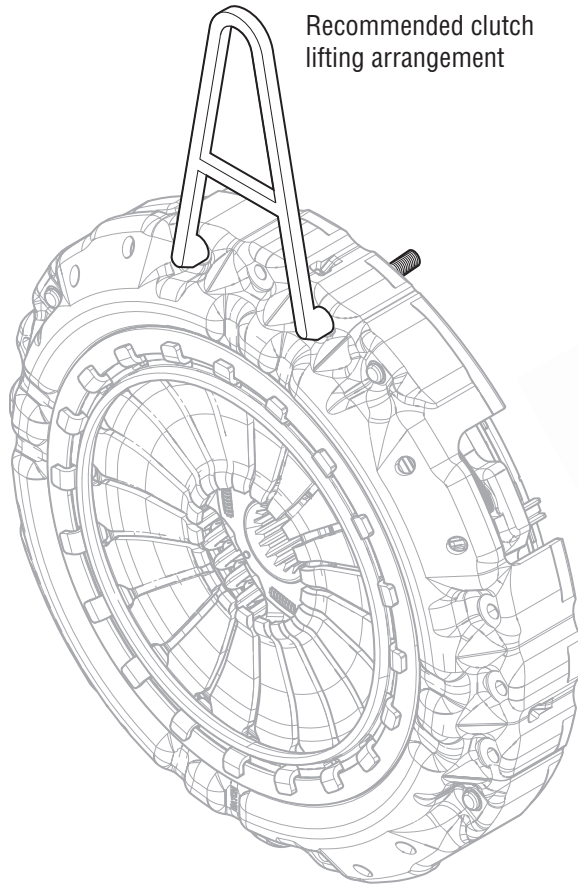

Important: Avoid harsh contact with the 4 control fingers when handling clutch assembly

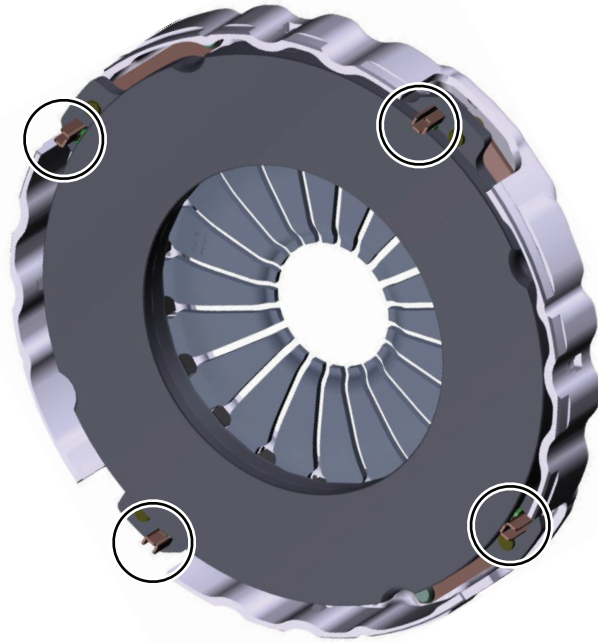

Transmission Assembly

Component Weight: 651 lb (295.3 kg)

Endurant XD Series transmissions are shipped to OEM assembly plants standing vertically on returnable steel shipping skids. The shipping skids have been in use for some time and are familiar to all OEM assembly plants. The OEM assembly plant should follow existing processes for returning the shipping skids to Eaton Cummins Automated Transmission Technologies or to a contracted third-party sequencer.

It is possible that Endurant XD Series transmissions will be mixed with other transmission models on a shipping skid. Each transmission will be clamped to the shipping skid by two opposing clamps contacting the transmission clutch housings.

NOTICE: Care must be taken to avoid product damage when lifting transmissions from the shipping skid by avoiding physical contact with electronic control modules, wiring harnesses, stub levers, air hoses, heat exchangers, and lubrication hoses.

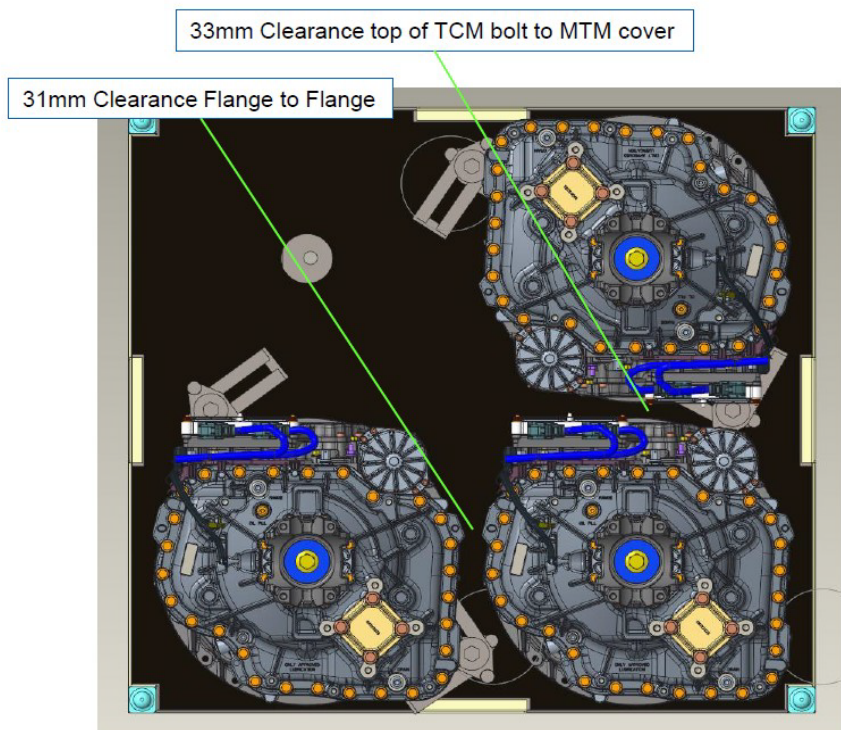
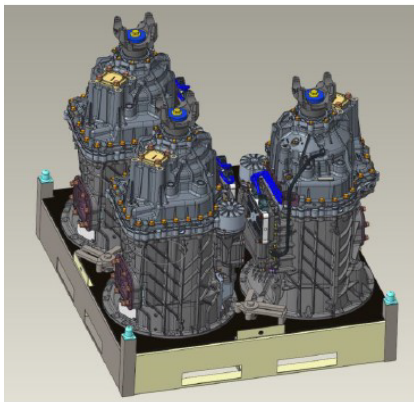

To remove transmissions from shipping skids, use a two-point lifting chain placed at the two rear-mounted transmission lifting eyes. Ensure each leg of the lifting chain is adjusted to the same length.

To lift transmission when in a horizontal position, use a two-point lifting chain placed at the two top-mounted transmission lifting eyes and ensure the lifting chain legs are adjusted to a length that matches a relative angle to the engine. The lifting eye positions shall not be changed on the transmission for installation.

Transmission Lifting Points

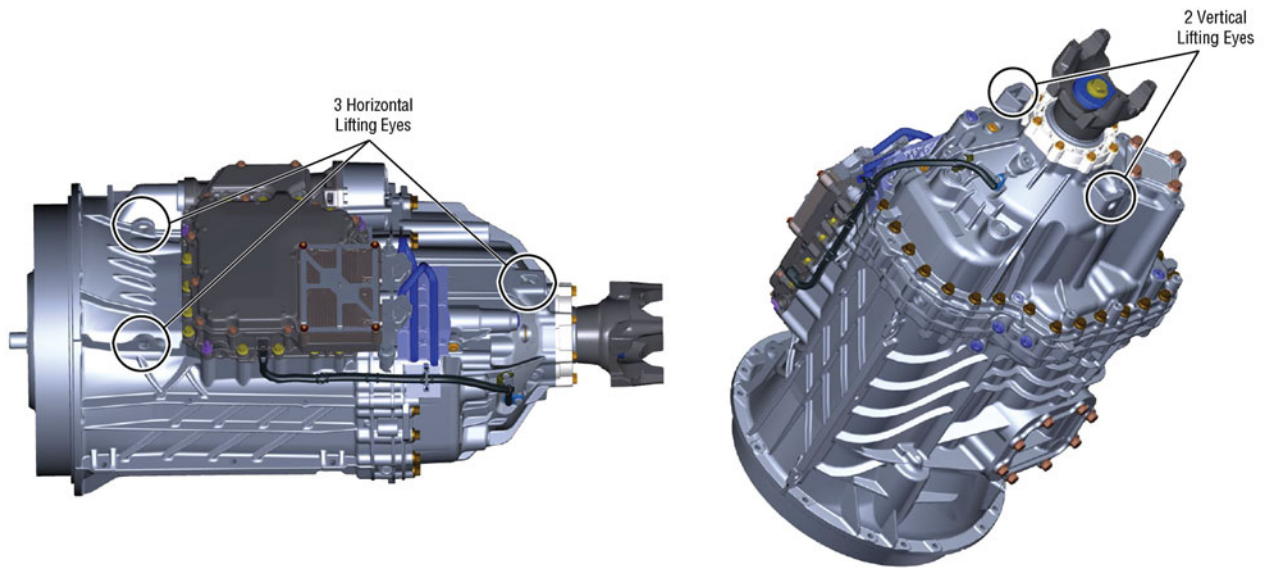

Clutch Installation

NOTICE: The clutch assembly procedure is the same for all clutch combinations in Section 1: Clutch Assembly.

NOTICE: Prior to clutch installation, the engine flywheel shall be cleaned of any oily residue, rust preventatives, and decals. Any oily residue, rust preventatives, or decals remaining on the engine flywheel will transfer to the organic facing of the driven disk and may result in reduced friction between the engine flywheel and clutch disk friction material.

NOTICE: Eaton recommends the clutch assembly be installed to the engine flywheel as a single component (clutch cover and driven disk combined). If the driven disk becomes separated from the clutch cover for any reason, the installer must observe the orientation instructions on the driven disk to ensure the driven disk is installed in the correct direction. Failure to install the clutch driven disk in the correct orientation will prevent the driven disk from contacting the engine flywheel and prevent the clutch cover from being installed.

- Recommended lifting device: Use a lifting device designed to lift the clutch assembly using two fastener holes on a single leg of the clutch cover. See example of clutch lifting device shown in Component Packaging and Handling.
- On the engine flywheel, install two temporary alignment studs to align the clutch cover pilot with the engine flywheel pilot and to support the weight of the clutch assembly. It is recommended to install the temporary alignment studs at the approximate 3 o'clock and 9 o'clock positions. Exact placement of the temporary alignment studs will depend on the design of clutch lifting device used.

NOTICE: Eaton recommends the alignment studs be custom made for the Endurant XD Series clutch assembly. Recommend studs be machined to 10.5 mm diameter with 14 mm of thread engagement into the flywheel. Length of alignment studs may be made to plant preference. Use of standard M10 bolts as alignment dowels may lead to a mis-piloted clutch-to-flywheel joint.

- Insert alignment shaft through rear of diaphragm spring and driven disk assembly. The alignment shaft (K-Line item number RR1064TR) is designed to allow lifting of the clutch cover and driven disk as a single assembly.
- Install the clutch assembly onto the engine flywheel ensuring the pilot stub of the alignment shaft is fully seated into the flywheel pilot bearing. Slide the clutch assembly forward on the alignment shaft until the clutch assembly contacts the engine flywheel.

NOTICE: When the clutch assembly initially contacts the engine flywheel, there will be an approximate 4 mm gap between the clutch cover and engine flywheel. Closing the gap requires overcoming an initial spring pressure of approximately 4,500-pounds, increasing to approximately 10,000-pounds of spring pressure when the clutch cover is fully seated against the flywheel. See notes below for recommended technique for installing clutch fasteners.

- Install 10 clutch assembly fasteners into open holes in clutch cover by hand. Use M10 x 1.5 x 80 mm, minimum class 10.9 fasteners.
- Beginning with the fastener closest to the 6 o'clock position, run all fasteners down to contact head of fastener with clutch cover. Do not exceed 4 lb ft of torque on fasteners at this step.

NOTICE: Failure to begin with the fastener closest to the 6 o'clock position may lead to a mis-piloted clutch-to-flywheel joint.

NOTICE: Eaton recommends the lifting device not be removed from the clutch cover until fasteners are in contact with clutch cover. Removing the lifting device prior to this step may lead to a mis-piloted clutch-to-flywheel joint.

- Beginning with the fastener closest to the 6 o'clock position, progressively tighten fasteners in a criss-cross pattern. Torque fasteners to OEM specification.

NOTICE: Due to the immense spring pressure involved, it is recommended to use a multi-spindle driver to evenly distribute the clutch clamp load across multiple fasteners at once. If a single-spindle driver is used, it is critical for the installer to progressively tighten each fastener in a crisscross pattern, touching each fastener several times, in order to maintain relatively even clamp load across each of the fasteners and to seat the clutch cover evenly. Failure to follow this technique may result in damaging the engine flywheel and clutch cover.

- Remove 2 alignment studs and replace with 2 additional clutch assembly fasteners. Torque fasteners to OEM specification.
- Use a light-weight hammer and a 3/8-inch flat-nose punch to lightly tap the 4 control fingers until contact with the engine flywheel.

NOTICE: Little force is required to seat the 4 control fingers to the engine flywheel. To avoid excessive force and potential damage to the control fingers, it is recommended to use a 6-ounce hammer and brass punch for this process.

- Remove the driven disk alignment shaft.

1 Insert alignment shaft hub through diaphragm spring.

2 Install clutch disk onto alignment shaft following orientation instruction on disk.

3 Install alignment dowels into flywheel at the 3 o'clock and 9 o'clock positions.

Note: See preceding notice for recommended alignment dowels.

4 Install 10 flanged bolts by hand. Use M10 x 1.5 x (length specified by OEM), minimum class 10.9 fasteners.

Run fasteners down to contact head of fastener with clutch cover. Do not exceed 4 lb-ft of torque on fasteners at this step.

Remove lifting device from clutch and install fasteners in place of lifting device.

Replace alignment dowels with 2 fasteners.

Torque fasteners in a crisscross pattern beginning with fastener closest to 6 o'clock position. Torque to 54.3 – 67.8 Nm (40 – 50 ft-lb).

NOTICE: It is recommended to use a multi-spindle driver to evenly distribute clutch clamp load across multiple fasteners at once.

If a single-spindle driver is used, it is critical for the installer to progressively tighten each fastener in a crisscross pattern, touching each fastener several times, in order to maintain even clamp load across each of the fasteners. Failure to follow this technique may result in damaging the engine flywheel and clutch cover.

5 Use a light-weight hammer and a 3/8-inch flat-nose punch to lightly tap the control fingers until in contact with the engine flywheel.

Note: Little force is required to seat control fingers.

6 Remove aligning tool.

Note: See following page for control finger detail.

Control Finger Detail

The image below shows the location of the four control fingers. For the purpose of this illustration the clutch assembly is rotated to place each grouping of fastener holes at 12, 3, 6, and 9 o'clock positions.

Note: The control fingers are located immediately to the left of each grouping of fastener holes.

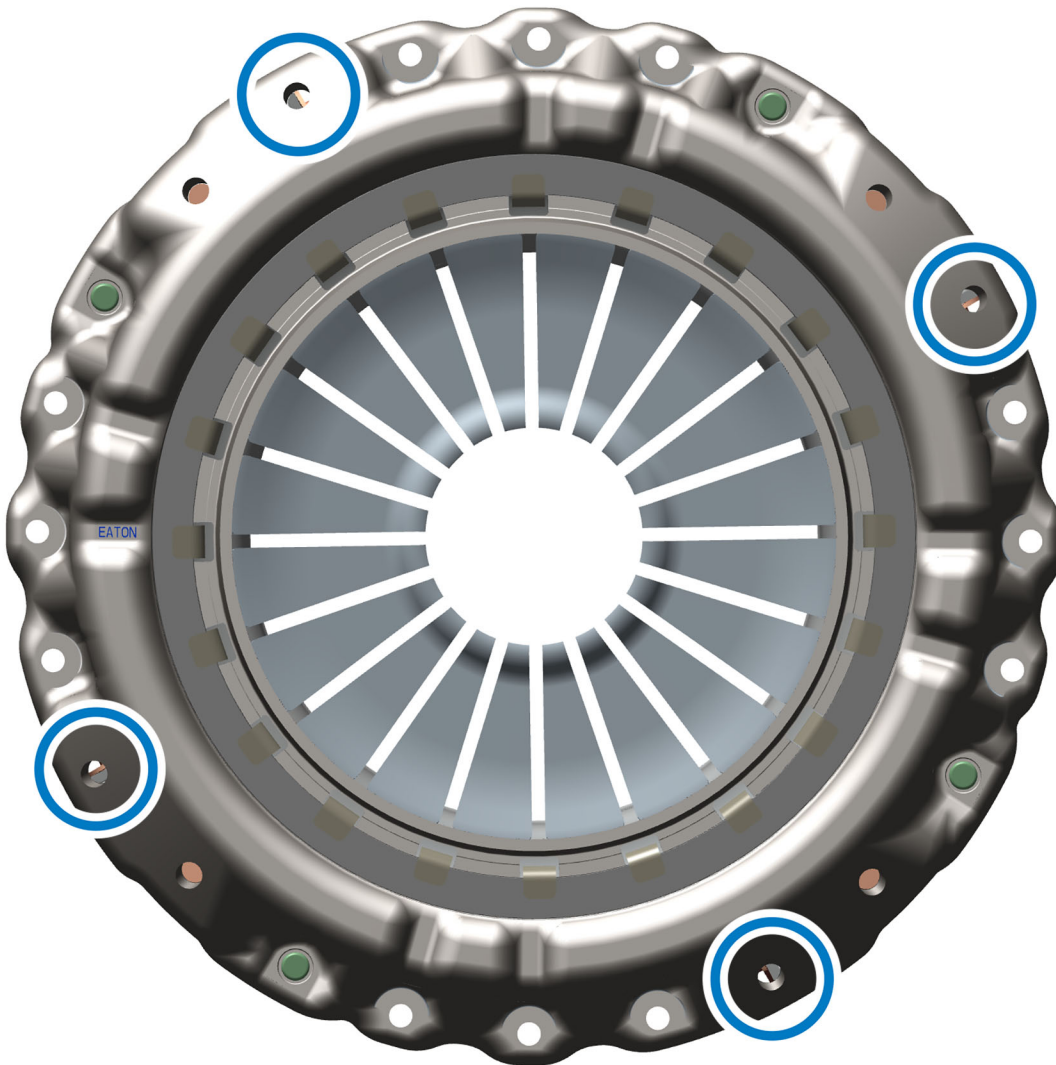

Transmission Preparation and Installation

End Yoke Retainer Design and Installation

All Endurant XD Series transmissions have a single-screw retainer design for the output yoke which uses a retainer plate beneath the retaining screw. Typically output yokes will be pre-installed although the OEM may have the option to install their own output yoke or replace the installed output yoke to accommodate changes in other vehicle specifications.

NOTICE: The transmission must be in gear when installing or replacing the output yoke.

NOTICE: A new output yoke retaining screw is required if the Eaton Cummins Automated Transmission Technologies installed output yoke is removed for any reason.

- Retaining screw part number: 10000949
- Tooling: 27 mm socket size
- Torque requirement: 455 – 509 lb ft (617 – 690 Nm)

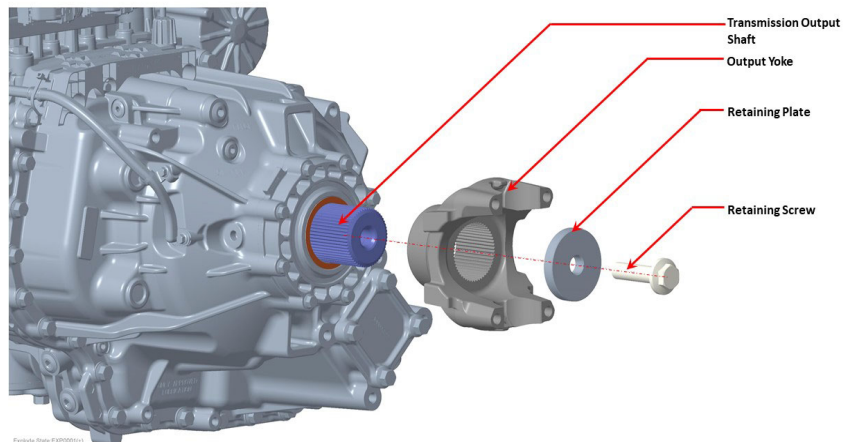

PTO Installation

Endurant XD Series is equipped with seals for both 8 bolt PTO and read four bolt PTO covers. The following diagram illustrates the assembly of the seals.

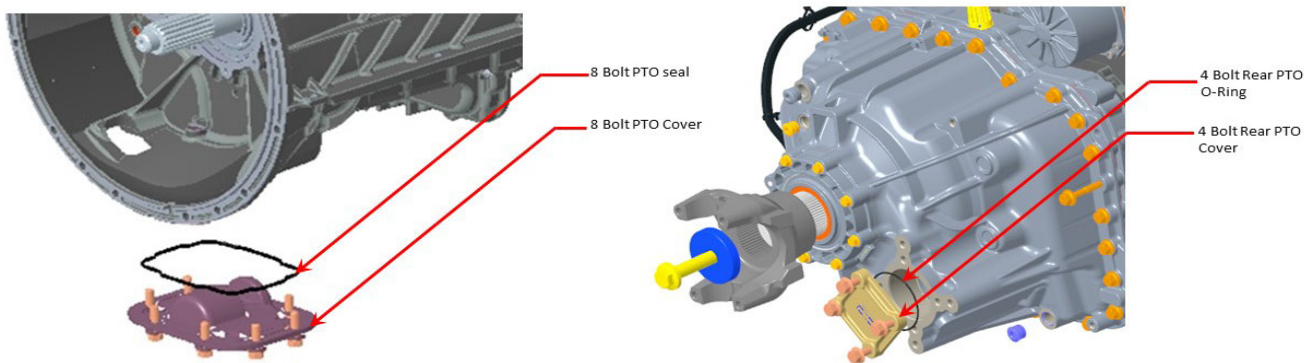

Assembly instructions for PTO installation must be obtained from the PTO manufacturer. The PTO manufacturer will typically include installation instructions in the box the PTO is shipped in. Contact the PTO manufacturer directly if installation instructions are unavailable.

Mounting Transmission to Engine

NOTICE: Action required prior to transmission installation

Endurant XD Series transmissions are shipped with the clutch release bearing and clutch release yoke pre-installed within the clutch housing. For shipping purposes the clutch release bearing and clutch release yoke are held into a retracted position by a plastic shipping cone which must be removed prior to transmission installation. The plastic shipping cone is attached to the transmission input shaft by a single retaining screw threaded into the input shaft pilot.

Removing the retaining screw requires an 8 mm hex drive socket or wrench.

The plastic shipping cone and retaining screw may be discarded or recycled per the OEM plant's discretion.

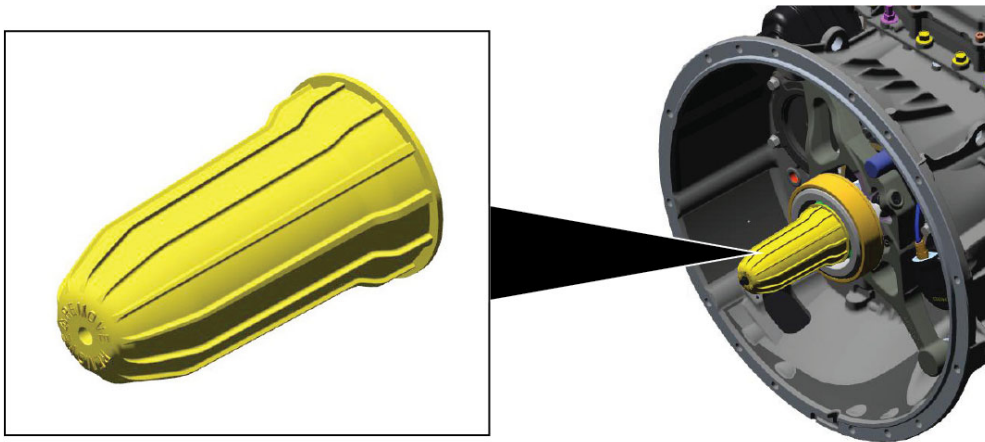

- Ensure the engine flywheel housing and transmission clutch housing mating surfaces are free of damage, debris, paint or rust prior to transmission installation.
- Ensure the transmission input shaft is free of damage, debris, paint or rust prior to transmission installation.
- Use a two-point lifting chain placed at the two top-mounted transmission lifting eyes and ensure the lifting chain is adjusted to the same relative angle as the engine. The lifting eye positions shall not be changed on the transmission for installation.
- The face of the engine flywheel housing and the face of the transmission clutch housing shall be parallel during installation. If the transmission input shaft splines are properly aligned to the clutch driven disk, very little effort is required to spline the transmission input shaft through the clutch disk.
- Rotate the transmission output yoke to align the input shaft splines with the clutch disk splines while pushing the transmission assembly toward the engine.
- If interference is encountered, move the transmission away from the engine to investigate the cause. The use of excessive force to overcome misalignment may cause damage to the transmission input shaft and the clutch driven disk.
- Once the transmission is seated against the engine flywheel housing, align the clutch housing fastener holes with the engine flywheel housing fastener holes and install all fasteners.

NOTICE: The clutch housing shall be flush against the engine flywheel housing before tightening any fasteners. Do not use the fasteners to close any gap between the transmission clutch housing and engine flywheel housing.

- Torque all transmission clutch housing cap screws to OEM specification.



WARNING: Do not remove the transmission lifting chains until all clutch housing mounting fasteners have been torqued to OEM specification. Early removal of lifting chains prior to fully securing all fasteners may result in the transmission becoming detached from the engine resulting in serious injury or death.

NOTICE: The OEM is responsible for determining the proper fasteners for the interface of the clutch housing to the engine flywheel housing. The clutch housing fastener holes are sized to 11.99 mm +/- 0.12 mm.

Pull-to-Neutral and Clutch Actuator Unlock

All Endurant XD Series transmissions are shipped in gear and with the linear clutch actuator (LCA) in a retracted position. Having the transmission in gear aids the installer to align the transmission input shaft splines with the clutch disk splines by simply rotating the transmission output shaft during installation. Shipping the transmission with the LCA retracted is necessary to prevent the clutch release bearing from contacting the clutch assembly during transmission installation.



WARNING: Only supply compressed air to the transmission when the transmission is fully secured to an engine. The clutch actuator is external to the transmission and has the potential to actuate should compressed air be supplied to the transmission before the transmission is installed. Failure to fully secure the transmission to an engine before applying compressed air may result in serious injury or death.

The OEM assembly process shall include tooling necessary for placing the transmission in neutral and for unlocking the LCA once the transmission is installed to the engine. The MTM must have air pressure in order to neutralize the transmission. Follow the air system requirements for proper connection to the MTM:

- Air fitting requirement: M18 x 1.5 O-ring port per ISO6149-1 O-Ring Boss (ORB) with minimum of 0.5" i.d. [1.3cm] diameter air supply line
- Air supply requirement: 50 – 150 PSI
- Air quality requirements: Air quality shall meet or exceed ISO 8573-1:2010 7.3.4.
 - Air quality for solid contamination shall meet a minimum of ISO 8573 Class 7 (between 5mg/m³ and 10mg/m³ at 20° C, 1bar, 0 relative water vapor pressure).
 - Air quality for oil contamination shall meet a minimum of ISO 8573-1 Class 4 (less than 5mg/m³ of liquid/aerosol/vapor at 20° C, 1bar, 0 relative water vapor pressure).

Eaton will continue to supply the 'Pull-to-Neutral' tool that is required for communicating with the transmission TCM. The tool is similar to that used with UltraShift PLUS and Fuller Advantage transmissions but will include the following upgrades:

- Backward compatibility with UltraShift PLUS and Fuller Advantage transmissions utilizing separate cables for the respective TCM connections.
- Removable cables that can be replaced for maintenance needs within the OEM plant.
- Indicator lights that report successful communication with TCM, battery charge status, and neutral confirmation.
- Improved battery charging circuit that allows tool remain connected to AC power if desired.

Transmission Lubrication

NOTICE: The transmission lubricant shall be approved per Eaton PS-386 requirements as documented in the Lubrication Manual TCMT0020.

A list of approved lubricants and suppliers can be found in the Approved Lubricant Supplier Manual TCMT0020. Not using the required lubricant will result in degraded performance and shortened life of the product.

- Lubrication capacity: 12 liters
- Additives and/or friction modifiers are not approved. Additives of any kind will result in unpredictable consequences. No liability of any kind will be accepted by Eaton for any damage resulting from the use of such additives.
- Failure to use the required lubricant will affect the transmission performance and the warranty coverage.
- All approved lubricants are required to display the PS-386 approved logo.



Lubrication Fill Procedure

Endurant XD Series transmissions shall be filled with lubrication using a fill hole located at the top rear of the transmission rear case.

- Lubrication fill hole diameter: 16mm
- Lubrication fill plug drive: M18 x 1.5, 6mm Allen head inside hex
- Lubrication fill plug torque: 18 – 22 lb. ft. (24.5 – 29.5 Nm)

To install lubrication:

- Remove fill plug from top rear of transmission rear case.
- Follow established transmission lubrication fill process for selecting and dispensing lubrication. Ensure 12 liters of lubricant has been dispensed.
- Reinstall fill location plug and torque plug to 18 – 22 lb. ft. (24.5 – 29.5 Nm).
- Clean any lubrication residue from around the fill plug.

NOTICE: The OEM plant may recognize a removable plug located on the lower left side of the transmission that is similar to the top rear fill hole plug. This plug is intended for verifying lubrication fill and is not recommended for use of filling the transmission due to proximity of internal gearing that restricts fill rate and introduces a high risk of transmission lubrication splashing back through the hole.

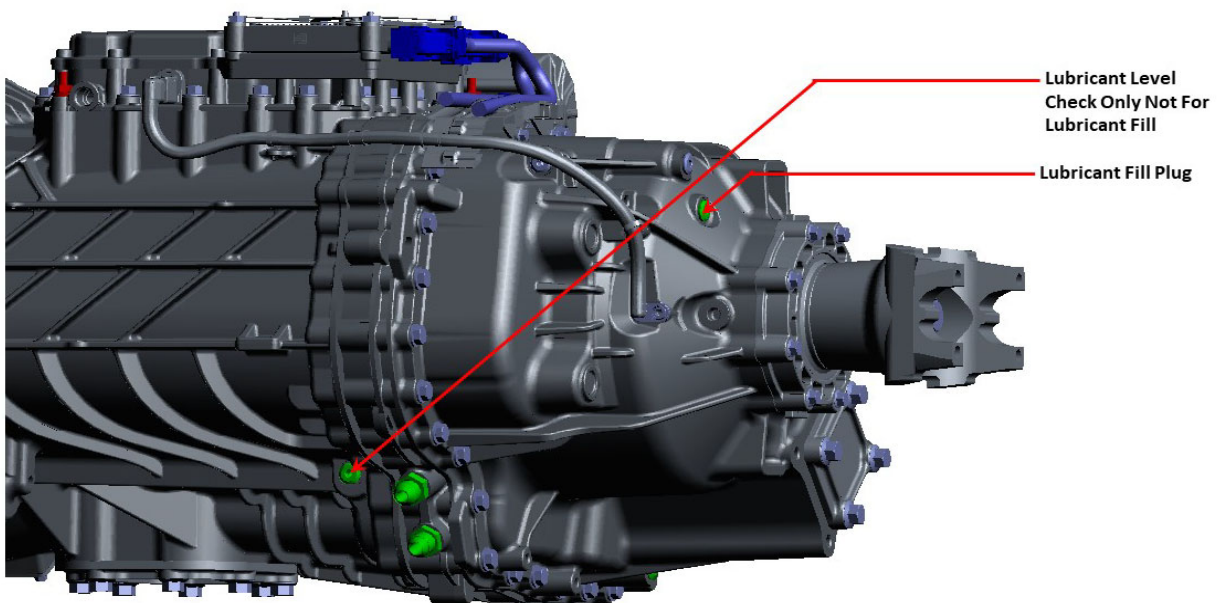

Verifying Lubrication Level in Vehicle

- Place vehicle on level ground and shut off engine.
- Remove lower left side check plug (M22x1.5 8mm hex key) from transmission case.
- Fill the oil if necessary through lubricant fill hole till the oil drips out of the lubricant check hole.
- Reinstall the fill hole plug and the check plug and torque plug to 18 – 22 lb. ft. (24.5 – 29.5 Nm).
- Clean any lubrication residue from around the fill plug.

Pneumatic Connections

A transmission air supply fitting shall be installed into the mechatronic transmission module (MTM) using a metric straight O-ring port fitting per ISO6149-1 M18x1.5 O-ring boss (ORB).

NOTICE: Fitting torque (for fitting type specified above): Typical 70 Nm

The transmission shall be connected to an air supply tank by a high integrity air hose of at least 0.50 inch (12 mm) internal diameter. Fittings used on the air supply hose shall also have a minimum of 0.50 inch (12 mm) internal diameter. The transmission air supply is required to be routed from the air tank, which supplies air to either the front or rear vehicle service brakes and has a corresponding gage indicator in the cab.

NOTICE: Care should be used when routing the air supply to avoid kinks and close contact to heat sources.

NOTICE: Do not tie wrap airline to wire harness on transmission

NOTICE: Do not supply the transmission with untreated or unregulated shop air during the assembly process.

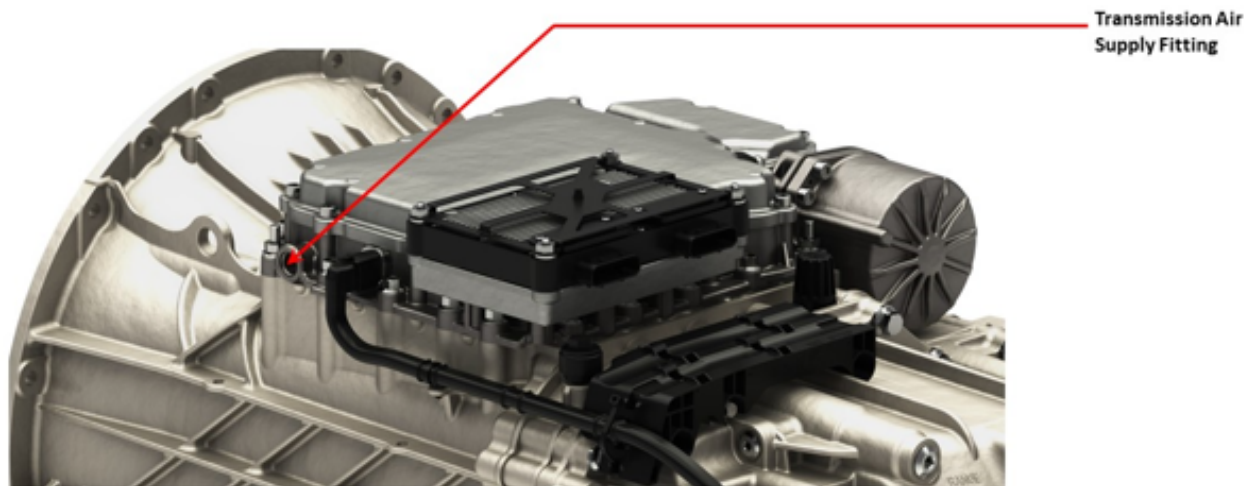

Electrical Connections

All Endurant XD Series transmissions include two standard electrical connections and one optional electrical connection between the vehicle and transmission. The standard electrical connections are a vehicle interface harness to the transmission control module (TCM) and to a transmission fluid pressure sensor. The optional connections is for a body connection to the TCM.

- The transmission will be delivered with both TCM connectors covered by environmental shipping caps (Delphi P/N 13885475).
- In all vehicle configurations, the environmental cap for the vehicle connector of the TCM shall be removed and discarded to allow installation of the vehicle interface harness.
- In some vehicle configurations, installation of a body connector may not be required. In these instances, the environmental cap shall remain on the TCM body connector to protect against the elements. When the body connector is present in the OEM vehicle harness, the environmental cap located on the body connector of TCM may be discarded.
- The fluid pressure sensor is installed, the sensor will be covered with an environmental shipping cap. The shipping cap shall be removed and discarded to allow connection to the OEM vehicle harness.

OEM Interface Harnesses to TCM:

- The transmission is supplied with an OEM harness clipping bracket installed directly behind the TCM.
- The clipping bracket is molded with 4 slots designed for easy installation of plastic cable ties used to secure the OEM harnesses.
- The OEM vehicle harness (and body harness where used) shall be secured to the bracket with plastic cable ties. The images below illustrate bracket location and intended OEM harness routing.
- After installed to the TCM, the OEM vehicle harness (and body harness where used) shall be routed in manner as illustrated below to avoid strain on the harness at the connector body.

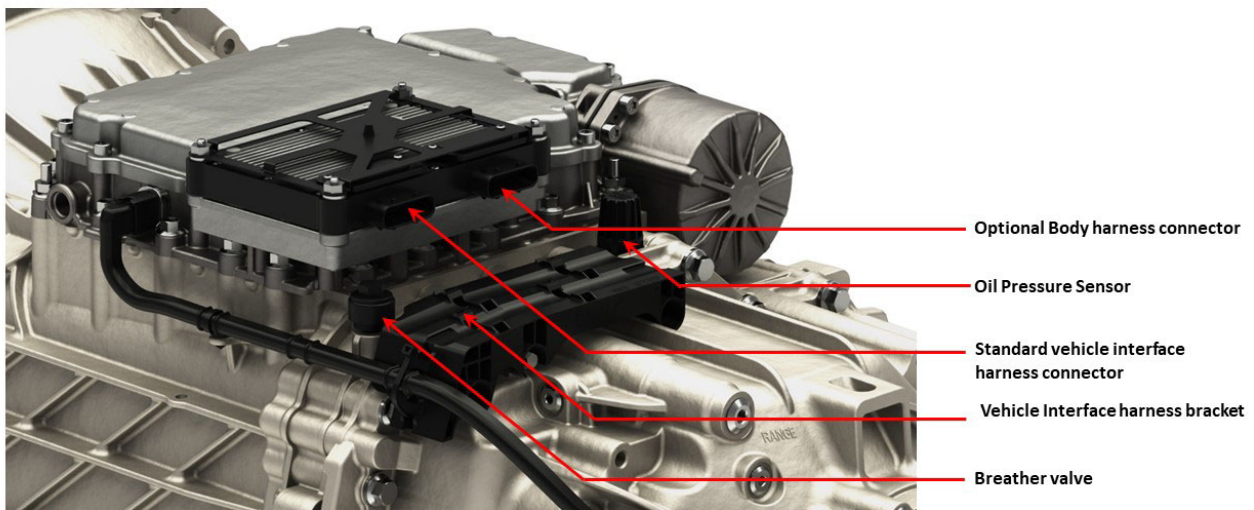

Vehicle Equipment Programming Station (VEPS)

The VEPS system permits the OEM to change or initialize the configurable parameters at the vehicle manufacturing facility. OEM engineering will generate a parameter file (.par) which contains the necessary data for the configurable parameters. The Vendor Component Program (VCP) is initiated using a command line instruction that lists the name of the desired parameter file. The VCP then communicates with the TCM, programming the desired parameters through the J1939 vehicle communications link. A verification file (.ver) is generated by the VCP to confirm the programming. The Automated Products VCP adheres to the following SAE and TMC standards:

- SAE J2461 - Vehicle Electronic Programming Stations, System Specification for Win32. The OEM is to provide the VEPS software and only the sections that are related to the VCP will be applied.
- SAE J2286 - Vendor Component Program Data File Interface for OEM Assembly Operations.
- TMC's RP1210 Version "A" – Windows Communication Application Program Interface. This document describes a common communications link between the vehicle and the Windows operating system.

Please contact the customer support engineering group for specific details deploying a production VEPS station for Endurant XD Series transmissions and reference the "OEM VEPS VCP Instruction Manual".

Refer to the "OEM VEPS VCP Instruction Manual" for configurable VEPS parameters.

Grade Sensor Calibration

The Endurant XD Series transmission includes a grade sensor that is used for intelligent start gear selection and input related to shift strategy. The OEM must calibrate the grade sensor specific to each vehicle's engine and chassis angle.

There are three options available for calibrating the grade sensor:

- The OEM may create a VEPS parameter to calibrate the grade sensor angle. All information needed to create the VEPS parameter can be found in the OEM VEPS VCP Instruction Manual which can be obtained through the customer support engineering group.
- Using existing grade sensor calibration boxes.
- Using the ServiceRanger PC-based diagnostic tool.

NOTICE: The OEM should expect an active fault code for the grade sensor (SPN 583, FMI 13: Out of Calibration) at initial power-up. The active fault will clear automatically once the grade sensor calibration is complete. The active fault code clearing is verification of a successful grade sensor calibration.

Process Requirements for Grade Sensor Calibration:

- Ground surface must be within +/-0.5% grade (.28 degrees) level.
- The vehicle's air suspension shall be fully aired.
- The vehicle's air suspension shall be set to correct and final ride height.
- The engine shall not be running during the grade sensor calibration.

NOTICE: Failure to calibrate the grade sensor prior to dyno may lead to unsatisfactory shift performance. This condition could be misinterpreted as a product defect and could lead the operator to unnecessary diagnostics.

NOTICE: Failure to adhere to ground surface requirements may lead to unsatisfactory shift performance. This condition could be misinterpreted as a product defect and could lead to unnecessary diagnostics.

End-of-Line Operation

Before Cranking Engine

- Verify Neutral is selected on the driver interface device.
- Turn the ignition key to the "On" position and observe the gear display.
 - An "N" shown in the gear display indicates the transmission has verified neutral.
 - An "F" shown in the gear display indicates the transmission is broadcasting an active fault code.
 - It is normal for the gear display to alternate between "N" and "F" when the transmission has verified neutral and is broadcasting an active fault code.
 - It is normal for the transmission to broadcast an active fault code related to the transmission grade sensor (SPN 583, FMI 13: Out of Calibration) at initial powerUp. The active fault will clear automatically once the grade sensor calibration is complete.
- Refer to the diagnostic procedure in this manual if the transmission broadcasts any active fault besides SPN 583, FMI 13,

Clutch Calibration Routine at Engine Start

The Endurant XD Series transmission automatically initiates a clutch calibration routine upon initial engine start. The clutch calibration is necessary for the transmission system to calculate the position of the clutch when torque is transferred from the engine to the transmission. A successful clutch calibration is required in order to select a transmission start gear from neutral. Air pressure of 90 Psi is required to start the clutch calibration. Ensuring the air pressure before starting the engine is recommended.

The transmission will broadcast “CC” (indicating clutch calibration in progress) to the gear display while the clutch calibration routine is active.

The transmission will not engage any start gear while the clutch calibration routine is active. If a start gear is selected while the clutch calibration routine is in progress, the mode requested will be denied.

The engine shall remain running until the clutch calibration routine is complete. Clutch calibration will be abandoned if the engine is shut off prior to the calibration being completed. The clutch calibration routine will automatically resume upon the next engine start.

The normal clutch calibration routine could take up to 60-seconds to complete. “CC” clearing from the gear display is verification of a successful clutch calibration.

NOTICE: If the initial clutch calibration routine fails for any reason, the Endurant XD Series system will attempt to successfully complete the clutch calibration 2 more times. If the system fails to complete a clutch calibration after 3 attempts, an active fault will be broadcast indicating the exact nature of the failed calibration. Refer to Troubleshooting Guide TRTS0960 for the correct diagnostic procedure. The transmission will continue to broadcast “CC” during an active clutch calibration or after 3 failed attempts. If the engine is shut off prior to the calibration being completed during the time-out period, the clutch calibration routine will be abandoned and will automatically restart upon the next engine start.

Assembly Review Process

Throughout product development and followed by regular production, OEM assembly plants are offered the service of performing joint process and procedure assessments geared towards collaborative continuous improvement and to identify any training opportunity or resources required. The following document is an installation review form prepared to aid OEM assembly plants in preparing for a joint assessment. The use of this form will allow for consistent analysis by supplier and the OEM and serve as a vehicle for clearly communicating opportunities for improvement.

Each assessment criteria is to be marked as either “Satisfactory” or “Unsatisfactory” using an “S” or “U” rating. “N/A” is used to note if a particular criterion is not assessed or is not applicable to a given OEM plant. Where any criteria are deemed as unsatisfactory, comments and rationale shall be captured in the “Observations and Recommendations” column of the review form.

Upon completion of the assessment, both parties will agree upon applicable action items and all action items will be tracked in a separate document that includes responsible parties’ names and action item dates. An assessment is not considered complete until all action items have been responded to by the responsible party (OEM or supplier).

Line Inspection Form

Assessment Criteria	Rating S (Satisfactory) U (Unsatisfactory) NA (Not Assessed / Not Applicable)	Observations and Recommendations
<p>Installation and assembly tools: Verify all necessary tools are available at point of use. Refer to complete list of suggested tools in section 11 of installation guide (TRIG0960).</p>		
<p>Clutch storage, removal from packaging, and general handling:</p> <p>Verify clutch assemblies are stored in a manner to prevent rust and physical damage.</p> <p>Verify lifting devices are designed to prevent physical damage to diaphragm spring, clutch cover, pressure plate, and driven disk assembly.</p> <p>Verify handling technique avoids harsh physical contact with pressure plate control fingers.</p>		
<p>Transmission storage, removal from packaging, and general handling:</p> <p>Verify transmission assemblies are stored in a manner to prevent rust and physical damage.</p> <p>Ensure lifting equipment and handling technique avoid physical damage to pre-installed output yokes, speed sensor harness, fluid pressure sensor, MTM, TCM, LCA, and all enclosures.</p>		
<p>Transmission assembly preparation:</p> <p>Output yoke installation or replacement: Verify retaining screw is torqued to 455 - 509 lb. ft. (617 - 690 Nm) NOTE: A new output yoke retaining screw is required if the factory installed output yoke is removed for any reason.</p> <p>Verify installation of air supply fitting does not damage MTM inlet threads.</p> <p>Verify that any brackets installed on transmission only utilize existing mounting provisions and that no transmission fasteners are removed.</p> <p>Verify that no OEM-installed equipment is attached to output shaft speed sensor harness.</p>		

Section 11

Assessment Criteria	Rating S (Satisfactory) U (Unsatisfactory) NA (Not Assessed / Not Applicable)	Observations and Recommendations
<p>PTO installation: Verify suitable tooling and procedure for cleaning PTO mounting surface after PTO cover is removed. Refer to PTO installation in section 11 of the installation guide (TRIG0960).</p>		
<p>Pilot bearing installation: Verify pilot bearing driver is designed to contact only the outer bearing race.</p>		
<p>Clutch installation:</p> <p>Verify appropriate work instructions or installation diagrams are available at point of installation.</p> <p>Verify flywheel is cleaned of any rust, rust preventatives, decals, or other oily residue or debris.</p> <p>Verify proper use of clutch assembly alignment shaft.</p> <p>Verify proper use of clutch-to-flywheel alignment and support dowels.</p> <p>Verify installers understand proper driven disk orientation</p> <p>Verify installation technique avoids "slamming" the pressure plate control fingers into the flywheel.</p> <p>Verify all clutch fasteners are torqued to OEM specification. NOTE: If a single-spindle driver is used, verify installer tightens all fasteners slowly and progressively touching each fastener multiple times.</p> <p>Verify operation for setting pressure plate control fingers to the flywheel.</p>		

Assessment Criteria	Rating S (Satisfactory) U (Unsatisfactory) NA (Not Assessed / Not Applicable)	Observations and Recommendations
<p>Transmission installation:</p> <p>Verify appropriate work instructions or installation diagrams are available at point of installation.</p> <p>Verify input shaft shipping cone is removed.</p> <p>Verify clutch release bearing is not allowed to escape clutch release yoke.</p> <p>Verify all legs of lifting chains are of suitable length to keep transmission level.</p> <p>Ensure lifting equipment and handling technique avoid physical damage to all transmission components.</p> <p>Verify clutch housing is fully seated to flywheel housing before any clutch housing fasteners are torqued.</p> <p>Verify grade of transmission mounting bolt meets OEM specification.</p> <p>Verify all clutch housing fasteners are torqued to OEM specification.</p>		
<p>Transmission pull-to-neutral and LCA unlock:</p> <p>Verify air supply pressure, MTM fitting, and air filtration meet all requirements documented in "Transmission Pull-to-Neutral and Clutch Actuator Unlock" of section 11 of the installation guide (TRIG0960).</p> <p>Verify TCM electrical connections are free of physical damage and debris.</p>		
<p>Lubrication fill:</p> <p>Verify lubricant meets Eaton specification PS-386</p> <p>Verify lubrication dispensing equipment avoids damaging transmission fill hole threads</p> <p>Verify 12 liters volume dispensed</p>		

Section 11

Assessment Criteria	Rating S (Satisfactory) U (Unsatisfactory) NA (Not Assessed / Not Applicable)	Observations and Recommendations
<p>TCM connections and OEM harness routing and clipping:</p> <p>Verify installers are properly latching TCM connectors</p> <p>Verify Eaton-provided harness anchor points or Eaton-approved alternative anchor points are utilized for TCM harness clipping.</p> <p>Verify no sharp bends in TCM harnesses. NOTE: The recommended bend radius of an individual cables is 2.5 times greater than the diameter of the individual cable.</p> <p>Verify suitable strain relief at TCM harness connections.</p> <p>Verify that any brackets installed on transmission only utilize existing mounting provisions and that no transmission fasteners are removed.</p>		
<p>Grade Sensor calibration: Verify calibration is completed with vehicle at +/- 0.5% grade (0.28degrees) to ground surface.</p>		
<p>Functional check:</p> <p>Verify "service light / service warning" functions correctly.</p> <p>Verify gear display functions correctly.</p> <p>Verify engine does not crank with shift device in any position other than neutral or park.</p> <p>Verify forward and reverse gear selection requires service brake application.</p> <p>Verify correct function of shift device in all modes of operation.</p>		
<p>VEPS: Verify correct calibration file is installed.</p>		
<p>Fuse inspection:</p> <p>Verify a single 10-amp ignition bus fuse.</p> <p>Verify dual (2) 15-amp main power fuses.</p>		

Assessment Criteria	Rating S (Satisfactory) U (Unsatisfactory) NA (Not Assessed / Not Applicable)	Observations and Recommendations
<p>Offline / Repair:</p> <p>Verify repair technicians have access to troubleshooting guides.</p> <p>Verify ServiceRanger is updated to latest release.</p> <p>Verify process to resolve and clear all fault codes before vehicle is released.</p>		

Diagnostic Procedure

A *Purpose: Document the vehicle symptom and check for Active or Inactive fault codes.*

1. Document the vehicle symptoms by completing the Driver Questionnaire on page 13.
2. Set vehicle parking brake and chock wheels.
3. Key on with engine off.
4. Connect ServiceRanger.
5. Select "Service Activity Report".
6. Enter information and select "Start Report".

Note: Fault code and transmission information is downloaded into the report.

7. Select "Send to Eaton".

Note: Internet connection is required.

8. Retrieve and record the transmission fault codes and FMLs, and their occurrences and timestamps.
 - If a vehicle/engine fault code(s) is Active, contact OEM for further diagnostic instructions.
 - If a transmission fault code(s) is Active, go to **Step G**.
 - If a transmission fault code(s) is Inactive, go to **Step B**.
 - If a transmission fault code is not set, go to **Step C**.
 - If ServiceRanger does not connect to the Transmission Control Module (TCM), go to the *Power-Up Sequence* on page 34.

B *Purpose: Clear Inactive Transmission Fault Code(s).*

1. Key on with engine off.
2. Connect ServiceRanger.
3. Go To Fault Codes.
 - Select "Clear Eaton Faults" and follow on-screen prompts. Go to **Step C**.

C *Purpose: Verify the engine cranks.*

1. Key on with engine running.
 - If the engine cranks and runs, go to **Step D**.
 - If the display indicates "F" during the engine crank or while the engine is running, retrieve fault code(s) with ServiceRanger. Go to **Step G**.
 - If the engine does not crank and the display indicates "N", go to *Start Enable Relay Contact Test* on page 661.

Note: If the engine was shut off with the transmission in gear, confirm the vehicle parking brake is set and service brake is depressed when attempting to start the engine.

D **Purpose:** Verify the transmission engages a gear from Neutral.

1. Key on with engine running.
2. Depress and hold the Service Brake.
3. Select a forward and reverse Shift Mode from Neutral.
 - If the transmission engages a gear, re-select Neutral mode. Go to **Step E**.
 - If the display indicates "F" during the mode selection and/or engagement of a gear, re-select Neutral mode. Retrieve fault code(s) with ServiceRanger, go to **Step G**.
 - If the transmission does not engage a gear and the display indicates "N", re-select Neutral mode and go to the *Brake Switch Functionality Test* on page 671.

E **Purpose:** Operate vehicle (road test) and attempt to duplicate the vehicle symptom.

1. Drive or operate the vehicle (road test), attempt to duplicate the vehicle symptom and set a fault code under the conditions reported in the Driver Questionnaire.
 - If the symptom was duplicated and/or the display indicated "F", go to **Step F**.
 - If the symptom was not duplicated, no problem was found. Contact Eaton Cummins Automated Transmission Technologies for further diagnostic instructions. For Help Line phone numbers, go to *Contact Information* on page 2.

F **Purpose:** Check for Active or Inactive fault codes.

1. Set vehicle parking brake and chock wheels.
2. Key off and allow the TCM to perform a complete power down.
3. Key on with engine off.
4. Connect ServiceRanger.
5. Select "Service Activity Report".
6. Enter information and select "Start Report".

Note: Fault code and transmission information is downloaded into the report.
7. Select "Send to Eaton".

Note: Internet connection is required.

- If a vehicle/engine fault code(s) set during the road test, contact OEM for further diagnostic instructions.
- If a transmission fault code(s) set during the road test, go to **Step G**.
- If a fault code did not set during the road test and the symptom was duplicated, go to the *Transmission Shift Complaint* on page 674.

G

Purpose: Prioritize fault codes for troubleshooting.

1. Determine the fault code to troubleshoot first by using the priority index below (with 1 highest priority and 4 least priority).
 - Priority 1: Vehicle Interface Fault Codes 100-199
 - Priority 2: Component Fault Codes 200-499
 - Priority 3: System Fault Codes 500-899
 - Priority 4: Feature Fault Codes 900-999
2. Go to the *Fault Code Isolation Procedure Index* on page 19 and troubleshoot the fault code with the highest priority level.
 - If more than one fault code within a level applies, troubleshoot Active fault codes before Inactive fault codes.
 - If only Inactive fault codes are present, troubleshoot the fault code that has the highest occurrence count or most recent timestamp.
 - If no fault codes are found, match the vehicle symptom to the appropriate item in the *Symptom-Driven Diagnostics Index* on page 15

Troubleshooting and Test Equipment Recommendations

- Refer to Troubleshooting Guide TRTS0960 for all advanced diagnostic and troubleshooting procedures.
- The removal of fuses is not recommended as the method of disconnecting power from the TCM. Making and breaking a circuit through tin-plated terminals (e.g., ring terminals, fuses) will destroy the plating on the terminal.
- Removing 20-way connectors that are being supplied with power is not recommended as a method of disconnecting power from the TCM.
- Opening a switch contact on the main power link is the recommended method of interrupting power.
- Avoid harness Probing Damage Alert. Never puncture cable insulations with a probe to verify voltage or to check continuity. Damage to the wire insulation can lead to immediate or future failures of the harness or electronic control unit due to short circuits, water entry or corrosion.

Change Log

Section	Change Details	Date	Author
General Info	Reformatting	October 2024	Devin Matos
Front Cover	Removed Note	September 2022	Ravi Yetchina
N/A	Published TRIG0960EN-US	June 2022	Ravi Yetchina

Copyright Eaton Cummins Automated Transmission Technologies, 2024. Eaton Cummins Automated Transmission Technologies hereby grant their customers, vendors, or distributors permission to freely copy, reproduce and/or distribute this document in printed format. It may be copied only in its entirety without any changes or modifications. THIS INFORMATION IS NOT INTENDED FOR SALE OR RESALE, AND THIS NOTICE MUST REMAIN ON ALL COPIES.

Note: Features and specifications listed in this document are subject to change without notice and represent the maximum capabilities of the software and products with all options installed. Although every attempt has been made to ensure the accuracy of information contained within, Eaton makes no representation about the completeness, correctness or accuracy and assumes no responsibility for any errors or omissions. Features and functionality may vary depending on selected options.

For spec'ing or service assistance, call 1-800-826-HELP (4357) or visit www.eaton.com/roadranger. In Mexico, call 001-800-826-4357.

Roadranger: Eaton and trusted partners providing the best products and services in the industry, ensuring more time on the road.

Eaton Cummins Automated Transmission Technologies
P.O. Box 4013
Kalamazoo, MI 49003 USA
800-826-HELP (4357)
www.eaton.com/roadranger

Printed in USA

