

Endurant XD Series Automated Transmission TRDR0960 EN-US

November 2023



BACKED BY
Roadranger
SUPPORT

Table of Contents

General Information

Warnings and Cautions	1
-----------------------------	---

Operation

Transmission Driver Interface Device Modes	3
Gear Display	4
Start-Up and Power Down	6
Reverse Mode	8
Neutral Mode	9
Drive Mode (Auto Mode)	10
MANUAL Mode	11
LOW Mode	13
Transmission MANUAL / LOW Mode Override	14
Snow/Ice Operation	15
Trailer Operation	16
Features	17
Hill Start Aid	17
Vehicle Facing Uphill – Forward Mode (HSA)	18
Vehicle Facing Downhill - Reverse Mode (HSA)	18
Clutch Abuse Protection	19
Engine Overspeed Protection	20
Shuttle Shifting	20
Smart Gear Selection	20
Auto Neutral	21
Load Based Shifting	21
Coast Mode	22
Neutral Coast Mode	23
Urge to Move (AutoLaunch)	24
Creep Mode	24
High Range Reverse	25
Rock Free Mode	26
Paving Assist	28

Table of Contents

Operation (Cont'd)

Force Neutral / Hold Neutral Operation	30
Secondary Configuration Mode	31
Transmission Power Take Off Operation	33
Stationary PTO Operation	34
Mobile PTO Operation	35
Split-Shaft PTO Operation	36
Auxiliary Transmission Operation	38
Two-Speed Axle Operation	39
Transmission Oil Display Message	40

Service and Maintenance

General Model Information	41
Serial Tag and Model Nomenclature	41
Model Number	41
Serial Number	41
Troubleshooting	42
Diagnostics	42
Transmission Reset Procedure	42
Transmission Air Supply	43
Proper Transmission Lubrication	44
Lubrication Specifications	44
Transmission Oil Level Inspection Procedure	45
Transmission Lubrication Change Intervals	46
Vehicle Towing	47
Limited Driveline-Connected Towing	48
Dynamometer Test Mode	49

Warnings and Cautions

The alert symbol, signal words (**DANGER**, **WARNING** and **CAUTION**) and statements throughout this manual indicate the potential severity of a situation. Ensure to read, understand and follow each statement to avoid vehicle damage, component damage, personal injury, severe injury and/or death.



DANGER: Indicates an immediate hazard. Failure to follow the indicated procedures will cause major vehicle component damage, severe injury or death.



WARNING: Indicates an immediate hazard. Failure to follow the indicated procedures may result in major vehicle component damage, severe injury or death.



CAUTION: Indicates a potential hazard. Failure to follow the indicated procedures could result in minor or moderate component damage and/or personal injury.

The **NOTICE** and **Note** statements through out this manual provide additional details required to avoid damaging a component or incorrectly completing a repair. Ensure to read, understand and follow each statement to properly complete a repair.

NOTICE: Indicates component or property damage could result if you do not follow the indicated procedure.

Note: Indicates additional detail that will aid in the repair of a component.



WARNING: Ensure to read, understand and follow each statement outlined below. Failure to read, understand and follow each statement outlined below may result in major vehicle component damage, property damage, severe injury or death.

- Read the entire driver instructions before operating this transmission system.
- If engine cranks in any gear lever position (shift mode) on the transmission driver interface device other than Neutral (N), service vehicle immediately.
- Before starting the engine, always be seated in the driver's seat, select Neutral (N) mode using the transmission driver interface device, confirm a solid "N" in the gear display, and apply the vehicle parking brake.

General Information

- Before working on a vehicle, parking the vehicle, or leaving the cab with the engine running, select Neutral (N) mode using the transmission driver interface device, confirm a solid “N” in the gear display, apply the vehicle parking brake, and chock the wheels.
- Always depress and hold the vehicle service brake pedal prior to selecting a gear lever position (shift mode) from Neutral (N) using the transmission driver interface device.
- Always ensure that fuel is at a sufficient operating level before operating vehicle. A loss of engine power could result in diminished transmission operation.
- Do not release the vehicle parking brake or attempt to select a gear lever position (shift mode) from Neutral (N) using the transmission driver interface device until the vehicle air system pressure is in the normal operating range.



CAUTION: Ensure to read, understand and follow each statement outlined below. Failure to read, understand and follow each statement outlined below could result in component damage.

- Before operating a Power Take-Off (PTO), refer to “Transmission Power Take Off Operation.”
- Prior to any type of welding on a vehicle equipped with this transmission system, disconnect the battery cables (+ and -).

Railroad Grade Crossing Requirements: It is a requirement that the driver of a commercial vehicle specified under paragraph A sections 1-6 of FMCSA regulation 392.10 need only cross railroad grade crossings in a gear that permits the vehicle to complete the crossing without a change of gears. Select MANUAL (M) mode using the transmission driver interface device to hold a transmission gear position while crossing a railroad grade, refer to “MANUAL Mode” on page 11.



WARNING: Failure to select MANUAL (M) mode to hold a transmission gear position while crossing a railroad grade could result in major vehicle component damage, property damage, severe injury or death.

Transmission Driver Interface Device Modes

The transmission driver interface device is an OEM component. Refer to OEM for more information on operation, including engine brake operation.

R	Selects Reverse mode	(see page 8 for details)
N	Selects Neutral mode, used for Start-Up and Power Down	(see page 9 for details)
D	Selects Drive mode	(see page 10 for details)
MANUAL	Selects MANUAL mode	(see page 11 for details)
LOW	Selects LOW mode	(see page 13 for details)
Upshift/ Downshift Function	Used to request Upshifts and Downshifts and to change start gears	

Note: The transmission system may automatically override or prevent the driver's Upshift or Downshift request on the transmission driver interface device or automatically initiate a gear change based on vehicle operating conditions. Refer to "Transmission MANUAL / LOW Mode Override" on page 14.

Operation

Gear Display

The gear display indicates the current gear position of the transmission. During an Upshift or Downshift the display may momentarily flash the target gear position.

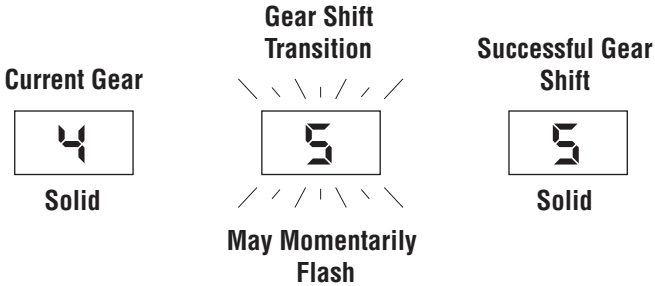

A dash “-” appears in the gear display when the transmission system cannot achieve Neutral gear position.



“CA” appears in the gear display when a clutch abuse protection event is occurring.



“AN” appears in the gear display when the transmission system goes into Auto Neutral.



“CC” appears in the gear display when the transmission system is performing a clutch calibration.



Operation

Note: Gear display indicators, messages, and tones will vary based on how the transmission system features and functions are configured in the Transmission Control Module (TCM) and how the OEM has implemented them. Refer to OEM for more information on the dashboard display.

Low Transmission Air Message: Allow the vehicle air system pressure to reach normal operating range prior to transmission system operation. Ensure the vehicle air system is operating and maintained per OEM guidelines.

NOTICE: If the low transmission air message is indicated, allow the engine to idle; shutting off the engine prolongs the condition. In most cases the transmission system will recover and towing the vehicle is not required.

Clutch Temperature Message: Safely and immediately discontinue the vehicle operation that is being performed which is causing increased clutch temperature. Depress and hold the vehicle service brake pedal or apply the vehicle parking brake and idle the engine until the message is no longer indicated.

NOTICE: If the clutch temperature message is indicated, allow the engine to idle; shutting off the engine prolongs the condition. In most cases the transmission system will recover and towing the vehicle is not required.

Note: If the low transmission air and/or clutch temperature message is indicated, and the condition no longer exists, some vehicle displays may require a manual reset to clear the message. Refer to OEM guidelines regarding the message reset procedure.

Transmission Fluid Temperature Message: Safely and immediately discontinue the operation that is being performed which is causing increased transmission fluid temperature. Depress and hold the vehicle service brake pedal or apply the vehicle parking brake and idle the engine until the message is no longer indicated.

NOTICE: If the transmission fluid temperature message is indicated, allow the engine to idle; shutting off the engine prolongs the condition. In most cases the transmission system will recover and towing the vehicle is not required.

Start-Up and Power Down

Start-Up

1. Turn ignition key to On with the engine off to allow the transmission system to power-up.

Note: Engine cranking is delayed until the transmission system power-up is complete and the gear display shows a solid "N" indicating the transmission is in neutral gear position.

2. Once a solid "N" is indicated in the gear display, start the engine.
3. Allow vehicle air system pressure to build to normal operating range.
4. Depress and hold the vehicle service brake pedal.

Note: If the vehicle service brake pedal is not depressed prior to selecting a gear lever position (shift mode) using the transmission driver interface device, the request will be denied.

5. Select the desired gear lever position (shift mode) using the transmission driver interface device.

Note: If the initial gear level position (shift mode) or start gear change request was denied, select Neutral (N) mode, depress and hold the vehicle service brake pedal and re-select.

Note: The transmission system may automatically override or prevent the driver's Upshift or Downshift request on the transmission driver interface device or automatically initiate a gear change based on vehicle operating conditions. Refer to "Transmission MANUAL / LOW Mode Override" on page 14.

6. Release the vehicle parking brake.

Power Down

1. Safely bring vehicle to a complete stop.
2. Continue to depress and hold the vehicle service brake pedal.
3. Select Neutral (N) mode using the transmission driver interface device.

Note: A solid “N” in the gear display indicates the transmission is in neutral gear position.

NOTICE: Neutral gear position should always be achieved before initiating a power down, except in cases of an emergency.

4. Apply the vehicle parking brake.



WARNING: Apply vehicle parking brake and follow OEM parking instructions. Failure to follow these instructions could cause unintended vehicle movement and may result in major vehicle component damage, property damage, severe injury or death.

5. Key off.

Operation

Reverse Mode

- Selects Reverse (R) mode and a reverse gear position.

Note: If the vehicle service brake pedal is not depressed prior to selecting Reverse (R) mode using the transmission driver interface device, the request will be denied. If the request was denied, select Neutral (N) mode, depress and hold the vehicle service brake pedal and re-select.

- The transmission system automatically selects a reverse start gear based on vehicle operating conditions such as: grade, load, and vehicle weight. Refer to “Smart Gear Selection” on page 20.
 - The driver may manually select a specific reverse start gear using the transmission driver interface device to Upshift or Downshift to the desired gear. Refer to OEM transmission driver interface device instructions.
- If vehicle speed is greater than 2 MPH, the transmission system will not allow engagement into a Reverse gear position.

Note: The transmission system may automatically override or prevent the driver’s Upshift or Downshift request on the transmission driver interface device or automatically initiate a gear change based on vehicle operating conditions. Refer to “Transmission MANUAL / LOW Mode Override” on page 14.



CAUTION: Do not depress and hold the vehicle accelerator pedal and service brake pedal at the same time during a vehicle launch (two-footing). Two-footing during a vehicle launch may cause the vehicle and cab to rock and bounce resulting in component damage, property damage and/or personal injury.

Neutral Mode

- Selects Neutral (N) mode and neutral gear position.
- Neutral is the initial gear position after Start-Up and the final gear position before Power Down.



WARNING: Apply vehicle parking brake and follow OEM parking instructions. Failure to follow these instructions could cause unintended vehicle movement and may result in major vehicle component damage, property damage, severe injury or death.

Note: When attempting to start the engine and the engine does not crank, confirm Neutral (N) is selected on the transmission driver interface device, confirm a solid “N” in the gear display, vehicle parking brake is applied and vehicle service brake pedal is depressed.

Drive Mode (Auto Mode)

- Selects Drive (D) mode and a forward gear position.

Note: If the vehicle service brake pedal is not depressed prior to selecting Drive (D) mode using the transmission driver interface device, the request will be denied. If the request was denied, select Neutral (N) mode, depress and hold the vehicle service brake pedal and re-select.

- The transmission system automatically selects a forward start gear based on vehicle operating conditions such as: grade, load, and vehicle weight. Refer to “Smart Gear Selection” on page 20.
 - The driver may manually select a specific forward start gear using the transmission driver interface device to Upshift or Downshift to the desired gear. Refer to OEM transmission driver interface device instructions.
- The transmission system automatically selects and engages the appropriate gears based on vehicle operating conditions.
 - The driver may request a gear shift while driving using the transmission driver interface device to Upshift or Downshift to a desired gear when the transmission system is near a shift point. Multiple gear Upshifts and Downshifts may be allowed, each Upshift/Downshift request equals one gear change.

Note: The transmission system may automatically override or prevent the driver’s Upshift or Downshift request on the transmission driver interface device or automatically initiate a gear change based on vehicle operating conditions. Refer to “Transmission MANUAL / LOW Mode Override” on page 14.

Note: Normal Drive mode is the recommended mode for optimal vehicle performance.



CAUTION: Do not depress and hold the vehicle accelerator pedal and service brake pedal at the same time during a vehicle launch (two-footing). Two-footing during a vehicle launch may cause the vehicle and cab to rock and bounce resulting in component damage, property damage and/or personal injury.

MANUAL Mode

MANUAL mode allows the driver to manually shift gears instead of letting the transmission system select gears automatically.

- The driver requests gear shifts using the transmission driver interface device to Upshift or Downshift to the desired gears. Multiple gear Upshifts and Downshifts may be allowed, each Upshift/Downshift request equals one gear change.
- The transmission system holds the current gear position until the driver initiates another Upshift or Downshift.

Note: The transmission system may automatically override or prevent the driver's Upshift or Downshift request on the transmission driver interface device or automatically initiate a gear change based on vehicle operating conditions. Refer to "Transmission MANUAL / LOW Mode Override" on page 14.

Note: Normal Drive mode is the recommended mode for optimal vehicle performance.

MANUAL / Hold Mode Gear

Hold Mode Gear is used to limit the use of MANUAL mode. When Hold Mode Gear is configured in the Transmission Control Module (TCM) to a specific gear, MANUAL mode becomes a hold gear function only. The default configuration for this function in the TCM is Disabled. The configuration can be changed using ServiceRanger.

- When MANUAL mode is selected and the transmission is in a gear equal to or greater than the configured Hold Mode Gear, the transmission will remain in the current gear; any Upshift or Downshift requests using the transmission driver interface device are not allowed and an audible tone may be emitted every 10 seconds.
- When MANUAL mode is selected and the transmission is in a gear less than the configured Hold Mode Gear, the transmission system allows normal MANUAL mode operation.

Note: The transmission system may automatically override or prevent the driver's Upshift or Downshift request on the transmission driver interface device or automatically initiate a gear change based on vehicle operating conditions. Refer to "Transmission MANUAL / LOW Mode Override" on page 14.

LOW Mode

LOW mode allows the driver to maximize engine braking and minimize the use of the vehicle service brake when driving down long grades or coming to a stop.

- The driver may select LOW mode using the transmission driver interface device while the vehicle is moving to prevent the transmission system from Upshifting, and support Downshifting at the earliest opportunity to enable higher engine RPM to promote maximum engine braking based on vehicle operating conditions.
- If LOW mode is selected using the transmission driver interface device while the vehicle is stationary, the transmission system will shift into 1st gear and remain there; any Upshift or Downshift requests using the transmission driver interface device are not allowed.



WARNING: On low friction surfaces refrain from engine braking when in LOW mode. Excessive engine braking at high engine RPM may cause a loss of traction and vehicle control and may result in major vehicle component damage, severe injury or death.

Note: The transmission system may automatically override or prevent the driver's Upshift or Downshift request on the transmission driver interface device or automatically initiate a gear change based on vehicle operating conditions. Refer to "Transmission MANUAL / LOW Mode Override" on page 14.

Transmission MANUAL / LOW Mode Override

The transmission system may automatically override or prevent the driver's Upshift or Downshift request on the transmission driver interface device or automatically initiate a gear change based on vehicle operating conditions. If the transmission system overrides or prevents a mode request, an audible tone may be emitted.

- If the transmission is being back-driven and the engine is approaching its high RPM level limit, the transmission system will override the MANUAL or LOW mode functions and perform an Upshift to prevent engine damage.

NOTICE: The transmission system initiates Upshifts for engine overspeed protection. Refer to “Engine Overspeed Protection” on page 20.

- If the driver manually selects a start gear using the transmission driver interface device that, when engaged, causes the engine to lug at a launch, the transmission system will override the MANUAL mode request and select an appropriate start gear to prevent engine lugging and possible damage.

Snow/Ice Operation

This transmission system is designed to work in coordination with the vehicle's traction control system to ensure optimal operation.

- If the driver observes low friction road conditions (rain, ice, snow, etc.) and does not want the transmission system to make a gear shift, the driver may select MANUAL (M) mode using the transmission driver interface device. The transmission system will remain in the current gear position until the driver re-selects Drive (D) mode or chooses to Upshift or Downshift using the transmission driver interface device once road conditions improve.

Trailer Operation

Trailer Connecting and Sliding Trailer Axle

- Prior to backing the vehicle under the trailer, ensure proper trailer height.
- Select the lowest available start gear for Drive (1st) or Reverse (R1) using the Downshift function as needed on the transmission driver interface device.
- Refer to vehicle and trailer manufacturer guidelines for unlocking, sliding and locking trailer axles.

Note: If repeat attempts are made and the automated clutch starts to overheat, the display may indicate “CA” (Clutch Abuse) and/or a clutch temperature message and an audible tone may be emitted. Refer to “Clutch Abuse Protection” on page 19.

Features

Hill Start Aid

- Hill Start Aid (HSA) requests the vehicle foundation brake system to temporarily hold (3 seconds) the vehicle in place when stopped on a grade of 3% or greater to allow the driver to transition from the vehicle service brake pedal to the vehicle accelerator pedal to achieve a controlled launch.
- When HSA is configured on, or Enabled, in the Transmission Control Module (TCM) and the vehicle is stopped on a grade of 3% or greater, the transmission system requests the vehicle electronic brake system keep the vehicle foundation brakes applied for 3 seconds after the driver releases the vehicle service brake pedal.
- The feature may be disabled for one launch by selecting the vehicle's HSA switch. When the HSA switch is selected, the lamp on the switch flashes indicating the feature is disabled. The feature automatically enables after a successful launch. Refer to OEM for information on operation of the HSA switch.

Note: The default configuration for this feature in the TCM is Enabled and can be configured to activate on a 1%, 2% or 3% grade using ServiceRanger.

NOTICE: If the vehicle electronic brake system is faulted and not working, this feature will not function. Refer to OEM for more information on the vehicle electronic brake system.

Operation

Vehicle Facing Uphill – Forward Mode (HSA)

1. The transmission system must be in Drive (D) mode and on an incline greater than the Hill Start Aid Threshold configuration setting (1%, 2% or 3%) in the Transmission Control Module (TCM).
2. Bring the vehicle to a stop, depress the vehicle service brake pedal then release the vehicle service brake pedal to launch the vehicle.

 **WARNING:** The transmission system HSA feature requests the vehicle electronic brake system to apply the vehicle foundation brakes for approximately 3 seconds. After 3 seconds, once the vehicle foundation brakes release, the vehicle may begin to move backward if the vehicle accelerator pedal is not depressed or the vehicle service brake pedal is not re-applied by the driver. Failure to depress the vehicle accelerator pedal or re-apply the vehicle service brake after the vehicle foundation brakes are released may cause unintended vehicle movement and may result in major vehicle component damage, property damage, severe injury or death.

Vehicle Facing Downhill - Reverse Mode (HSA)

1. The transmission system must be in Reverse (R) mode and on an incline greater than the Hill Start Aid Threshold configuration setting (1%, 2% or 3%) in the Transmission Control Module (TCM).
2. Bring the vehicle to a stop, depress the vehicle service brake pedal, then release the service brake pedal to launch the vehicle.

 **WARNING:** The transmission system HSA feature requests the vehicle electronic brake system to apply the vehicle foundation brakes for approximately 3 seconds. After 3 seconds, once the vehicle foundation brakes release, the vehicle may begin to move forward if the vehicle accelerator pedal is not depressed or the vehicle service brake pedal is not re-applied by the driver. Failure to depress the vehicle accelerator pedal or re-apply the vehicle service brake after the vehicle foundation brakes are released may cause unintended vehicle movement and may result in major vehicle component damage, property damage, severe injury or death.

Clutch Abuse Protection

- Clutch Abuse Protection alerts the driver that the clutch is overheating due to improper use. When a Clutch Abuse Protection event occurs, a “CA” is indicated in the gear display and/or a clutch temperature message is shown on the dashboard display and an audible tone may be emitted. During a Clutch Abuse Protection event only 1st and R1 gear launches are allowed; Urge to Move and Creep Mode may be disabled.
- When a Clutch Abuse Protection event occurs, safely and immediately discontinue the vehicle operation that is being performed which is causing the increased clutch temperature. Depress and hold the vehicle service brake pedal, or apply the vehicle parking brake, and idle the engine until the clutch temperature message is no longer indicated.

Note: Gear display indicators, messages, and tones will vary based on how the transmission system features and functions are configured in the Transmission Control Module (TCM) and how the OEM has implemented them. Refer to OEM for more information on the dashboard display.

Note: The default configuration for this feature in the TCM is Disabled. The configuration can be changed using ServiceRanger.

NOTICE: Allow the engine to idle; shutting off the engine prolongs the condition. In most cases the transmission system will recover and towing the vehicle is not required.

Follow the recommendations below to avoid increased clutch temperature:

- Prior to low speed maneuvering select the lowest available start gear for Drive (1st) or Reverse (R1) using the transmission driver interface device.
- During operation on a grade:
 - Bring the vehicle to a stop, depress and hold the vehicle service brake pedal until vehicle movement is required.

Note: Avoid using the vehicle accelerator pedal to hold the vehicle.
 - The transmission system Hill Start Aid (HSA) feature will request the vehicle electronic brake system to apply the vehicle foundation brakes for approximately 3 seconds when the driver is transitioning from the vehicle service brake pedal to the vehicle accelerator pedal.

Engine Overspeed Protection

- The transmission system will automatically Upshift if necessary to prevent engine overspeed in Drive, MANUAL and LOW modes.

Shuttle Shifting

- Shuttle shifting the transmission system between a forward or reverse mode is allowed if the vehicle speed is approximately 2 MPH or less.

Smart Gear Selection

- Smart Gear Selection automatically selects the appropriate forward or reverse start gear based on vehicle operating conditions such as: grade, load, and vehicle weight.
- The driver can change the start gear by manually Upshifting or Downshifting to the desired gear using the transmission driver interface device. Refer to OEM transmission driver interface device instructions.

Note: If the transmission system determines the manually requested start gear is not appropriate based on vehicle operating conditions an audible tone is emitted and the gear selection is not allowed.

Note: Minimum and maximum manual start gear selections are configured in the Transmission Control Module (TCM) using ServiceRanger.

- The transmission system will automatically perform "Skip shifting" if the system determines vehicle operating conditions such as: grade, vehicle weight, engine torque and driver demand are within limits that allow for proper gear engagement and vehicle operation.

Auto Neutral

- Auto Neutral automatically shifts the transmission system into a neutral state if the vehicle is left in a forward or reverse mode and the vehicle parking brake is applied. When this occurs, an “AN” is indicated in the gear display and an audible tone is emitted. A notification message may also appear in the dashboard display depending upon specific OEM implementation.
- To continue normal operation the driver must perform the following using the transmission driver interface device:
 - If Pushbutton controlled, select the desired forward or reverse mode with the vehicle service brake pedal depressed.
 - If stalk shifter controlled, select Neutral (N) mode then select the desired forward or reverse mode with the vehicle service brake pedal depressed.

Note: Gear display indicators, messages, and tones will vary based on how the transmission system features and functions are configured in the Transmission Control Module (TCM) and how the OEM has implemented them. Refer to OEM for more information on the dashboard display.

Load Based Shifting

- The transmission system constantly monitors the vehicle operating conditions and adapts the shift points to ensure the appropriate gear ratio is requested.

Coast Mode

- Coast Mode prevents the transmission system from downshifting through each lower gear when the driver is bringing the vehicle to a stop. If the transmission system determines the vehicle is coasting and is in a gear below the Coast Down Gear configured in the Transmission Control Module (TCM), the transmission system will automatically shift into a neutral state, allowing the vehicle to roll uninterrupted as the driver brings it to a stop. Once stopped, the transmission system automatically shifts into an appropriate start gear.
- If the driver depresses the vehicle accelerator pedal during a Coast Mode event, the transmission system will shift into an appropriate gear position for the current vehicle operating conditions.

Note: The Coast Down Gear is configured in the Transmission Control Module (TCM) at the OEM. The configuration can be changed using ServiceRanger.

Neutral Coast Mode

Neutral Coast Mode automatically shifts the transmission system into a neutral state on slight downhill grades when all of the following conditions are met:

- Vehicle Cruise Control is on
- Transmission is in Drive (D) mode
- Downhill grade identified by transmission system
- No engine power is being applied

When Neutral Coast Mode is active, the engine will drop to idle speed and the transmission system will automatically shift into a neutral state. During a Neutral Coast Mode event, the gear display may flash a gear number or “N”, or an OEM-specific character such as “SC”, depending upon the specific OEM implementation.

Note: Gear display indicators, messages, and tones will vary based on how the transmission system features and functions are configured in the Transmission Control Module (TCM) and how the OEM has implemented them. Refer to OEM for more information on the dashboard display.

- A flashing number in the gear display indicates the gear position that the transmission system will engage when necessary.
- The transmission system will inactivate Neutral Coast Mode and re-engage a gear if any of the following conditions occur:
 - Driver depresses vehicle service brake pedal
 - Driver depresses vehicle accelerator pedal
 - Vehicle Cruise Control is canceled or inactivated
 - Driver selects a shift mode other than Drive (D) on the transmission driver interface device
 - Driver performs an Upshift or Downshift request on the transmission driver interface device
 - Vehicle Cruise Control high or low set speeds are exceeded
 - Maximum vehicle grade is exceeded
 - A vehicle Adaptive Cruise Control system mode request is received

Note: Various brand names may be used for Neutral Coast systems. Contact the OEM for more information.

Operation

Urge to Move (AutoLaunch)

- Urge to Move allows the vehicle to automatically start moving at engine idle speed when the transmission system is in a forward or reverse mode and the driver releases the vehicle service brake pedal. After the vehicle has launched and begun moving, the transmission system will transition into Creep Mode.
- This feature is useful for stop and go applications allowing the vehicle to launch and creep without driver application of the vehicle accelerator pedal.

Note: The Urge to Move feature is configured in the Transmission Control Module (TCM) at the OEM. The configuration can be changed using ServiceRanger.

Creep Mode

- Creep Mode allows the vehicle to be driven at engine idle speed (no vehicle accelerator pedal input). Upshifts and Downshifts can be requested by the driver using the transmission driver interface device to increase or decrease the vehicle speed for existing vehicle operating conditions. Creep Mode becomes inactive once the vehicle accelerator pedal is depressed.
- This feature is useful for slow speed applications where slow and steady vehicle speed is required.

Note: The Creep Mode feature is configured in the Transmission Control Module (TCM) at the OEM. The configuration can be changed using ServiceRanger.

High Range Reverse

Note: High Range Reverse applies to Endurant XD Pro models only.

- The transmission system supports operation in 3 High Range Reverse gears (R4-R6) allowing for higher reverse operating speeds in certain vehicle applications.
- Based on vehicle operating conditions, the transmission system will allow High Range Reverse gears to be manually selected when the vehicle is stationary, driving in reverse, or during reverse Creep Mode.
- When the vehicle is stationary R4 is available to launch the vehicle. Once the vehicle is moving R5 and R6 can be selected.
- To manually select a High Range Reverse gear perform the following:
 1. Select Reverse (R) mode using the transmission driver interface device.
 2. Upshift to the desired High Range Reverse gear using the transmission driver interface device.

Note: If the transmission system determines the requested gear is not appropriate based on the vehicle operating conditions an audible tone is emitted and the gear selection is not allowed.

Note: Depressing the vehicle service brake pedal while moving to Downshift from High Range to Low Range is recommended to help the shift.

Note: The minimum and maximum selectable reverse start gears are configured in the Transmission Control Module (TCM) at the OEM. The configuration can be changed using ServiceRanger.

Rock Free Mode

- Rock Free Mode allows the driver to perform a vehicle “rocking” maneuver by depressing and releasing the vehicle accelerator pedal. This maneuver is useful in situations where the vehicle’s wheels are stuck in terrain depressions that are preventing vehicle movement.
- A dedicated momentary switch is used to activate Rock Free Mode. When activated, the transmission system disables the Urge to Move and Creep modes and allows the system to instantaneously apply and release the clutch when the driver depresses and releases the vehicle accelerator pedal; this action results in a “rocking” momentum to assist in freeing the vehicle from terrain depressions.

Note: Terrain conditions may limit the ability of this maneuver to free the vehicle.

- When Rock Free Mode is active, the transmission system automatically selects the lowest forward or reverse start gear available. The driver may manually select a specific start gear using the transmission driver interface device to Upshift or Downshift to the desired gear. Refer to OEM transmission driver interface device instructions.

Note: The transmission system may automatically override or prevent the driver’s Upshift or Downshift request on the transmission driver interface device or automatically initiate a gear change based on vehicle operating conditions. Refer to “Transmission MANUAL / LOW Mode Override” on page 14.

Note: Rock Free Mode is configured in the Transmission Control Module (TCM) at the OEM. The configuration can be changed using ServiceRanger.

To activate Rock Free Mode:

1. Ensure the vehicle is at a complete stop.
2. Depress and hold the vehicle service brake pedal.
3. Depress Rock Free Mode switch.

Note: An indicator lamp is illuminated and/or message is displayed when Rock Free Mode is active.

NOTICE: Some OEM switches may not illuminate, indicating the feature is active. Even though the lamp may not be illuminated, the feature may be functional.

4. Select a forward or reverse mode as required for vehicle movement.
5. Depress and release vehicle accelerator pedal to rock the vehicle, timing the apply and release to maximize the “rocking” momentum.

One of the following can deactivate Rock Free Mode:

- Sufficient vehicle motion (combination of speed, distance, and shiftable conditions).
- Depress Rock Free Mode switch.
- Initiate an Upshift request using the transmission driver interface device while vehicle is moving or vehicle accelerator pedal is depressed.
- Transmission system in Neutral (N) mode for an extended period.
- Apply the vehicle parking brake.

Operation

Paving Assist

Paving Assist allows the driver to go directly from Neutral (N) mode into Drive (D) mode without a vehicle service brake pedal application. This feature is useful in Paving applications to reduce the lumping of material when the dump vehicle is disengaging from the paving machine.

When ready to disengage, without depressing the vehicle service brake pedal, the driver selects Drive (D) mode using the transmission driver interface device and then depresses the vehicle accelerator pedal to move the vehicle forward and away from the paving machine.

When Paving Assist is active, a “PA” and the selected transmission start gear number will alternately flash in the gear display, and an audible tone may be emitted depending upon the specific OEM implementation.

Note: Gear display indicators, messages and tones will vary based on how the transmission system features and functions are configured in the Transmission Control Module (TCM) and how the OEM has implemented them. Refer to OEM for more information on the dashboard display.

Note: Hill Start Aid, Urge to Move, and Creep Mode are disabled when Paving Assist is active.

Vehicle and Transmission System Requirements:

- Vehicle stationary or moving in a forward direction at a speed less than 10 MPH.
- Neutral (N) mode is selected on the transmission driver interface device.
- Solid “N” is indicated in the gear display.

Note: The vehicle service brake pedal can be depressed while the vehicle is being pushed in Neutral (N) mode to slow the vehicle if necessary.

To activate Paving Assist:

1. While in Neutral (N) mode, without depressing the vehicle service brake pedal, select Drive (D) mode using the transmission driver interface device.

Note: This action is allowed if the vehicle is stationary or in motion.

2. Depress the vehicle accelerator pedal to move the vehicle forward and away from the paving machine. It is at this point Paving Assist is deactivated and the gear display will now show a solid gear number.

Note: If the vehicle accelerator pedal is not depressed within 6 seconds of selecting Drive (D) mode, Paving Assist is deactivated and the transmission system will go back into Neutral (N) mode and the gear display will change to a solid "N".

Note: The vehicle service brake pedal must be depressed to re-enable Hill Start Aid, Urge to Move and Creep Mode.

Note: Paving Assist is configured in the Transmission Control Module (TCM) at the OEM. The configuration can be changed using ServiceRanger.

Operation

Force Neutral / Hold Neutral Operation

Force Neutral or Hold Neutral operation allow the use of a separate vehicle integrated switch “input” circuit to override the driver’s action and “force”, or hold, the transmission in a neutral state to prevent vehicle motion while a vehicle specific feature is performed or chassis mounted equipment is operated or deployed (e.g. PTO, Crane, Lift, etc.). When Force Neutral or Hold Neutral is active, an “HN” is displayed in the gear display.

Note: Gear display indicators, messages and tones will vary based on how the transmission system features and functions are configured in the Transmission Control Module (TCM) and how the OEM has implemented them. Refer to OEM for more information on the dashboard display.

Note: The Force Neutral and Hold Neutral features are configured in the Transmission Control Module (TCM) at the OEM or body builder. The configuration can be changed using ServiceRanger.

Force Neutral Operation

When a vehicle integrated switch “input” circuit is activated, the transmission goes into a neutral state that is maintained until the switch “input” circuit is deactivated (off). The transmission system will deny any selection of a non-neutral mode (Drive/Reverse/Manual/Low) when the vehicle specific feature is on (switch “input” circuit is active).

Hold Neutral Operation

This feature requires preselecting Neutral (N) mode using the transmission driver interface device. Neutral (N) mode is maintained until the vehicle integrated switch “input” circuit is deactivated. The transmission system will deny any selection of a non-neutral mode (Drive/Reverse/Manual/Low) when the vehicle specific feature is on (switch “input” circuit is active).

Note: The Force Neutral and Hold Neutral features are configured in the Transmission Control Module (TCM) at the OEM or body builder.

Secondary Configuration Mode

- Secondary Configuration Mode allows the driver to switch between two different transmission operating modes (primary and secondary) depending on changing loads or vehicle operating conditions. This functionality is best used for vehicles that are operated in varied terrain or operations that require different shift strategies, launch or maneuvering characteristics, or ON/OFF road behaviors.
- A transmission driver interface device, such as a stalk shifter or dash mounted dedicated momentary switch, is used to switch between the primary and secondary configurations. Refer to OEM transmission driver interface device instructions.

Note: The transmission system will always default to its primary configuration mode at Start-Up.

Note: A configuration mode change can be made any time the vehicle is stopped or in motion.

- Once the secondary configuration mode is selected the transmission system will operate using the secondary configuration until returned to the primary configuration mode by any of the following conditions:
 - Driver uses transmission driver interface device (stalk shifter) or dash-mounted dedicated momentary switch to select primary configuration mode.
 - Driver completes a vehicle power cycle.
 - A configured secondary configuration “Cut-Out” condition, such as a time or speed threshold, is met.

Note: The Secondary Configuration is configured in the Transmission Control Module (TCM) at the OEM. The configuration can be changed using ServiceRanger.

Operation

To switch between Primary and Secondary Configuration Modes:

- If stalk shifter controlled:
 1. Hold stalk shifter in the Upshift position for 5 seconds.
 2. “C2” will appear in the gear display momentarily, indicating the transmission system is now operating in its secondary configuration mode.
 3. To return to primary configuration mode hold stalk shifter in the Upshift position for 5 seconds.
 4. “C1” will appear in the gear display momentarily, indicating the transmission system is now operating in its primary configuration mode.
- If using dash mounted dedicated momentary switch (optional):
 1. Press and hold the switch for 5 seconds.
 2. “C2” will appear in the gear display momentarily, indicating the transmission system is now operating in its secondary configuration mode.
 3. To return to primary configuration mode, press and hold the switch for 5 seconds.
 4. “C1” will appear in the gear display momentarily, indicating the transmission system is now operating in its primary configuration mode.

Note: An indicator lamp is illuminated and/or message may be displayed when the secondary configuration mode is active.

Transmission Power Take Off Operation

Transmission Power Take Off (PTO) functionality is available for stationary, mobile and split-shaft PTO applications. All transmissions are equipped with a bottom mount 8-bolt PTO opening and rear mount 4-Bolt PTO opening.

- Stationary PTO operation is performed with the transmission system in Neutral (N) mode with no vehicle movement.
- Mobile PTO operation is performed in a forward or reverse start gear. The transmission system automatically selects a start gear based on vehicle operating conditions such as: grade, load, and vehicle weight. Refer to “Smart Gear Selection” on page 20.
- Split-shaft PTO (SSPTO), or driveshaft PTO, is driven by the transmission’s output shaft. SSPTO operation is performed with the vehicle stationary and the vehicle parking brake set. SSPTO is used in stationary applications such as boom cranes and vacuum systems.

Note: Mobile SSPTO operation is not allowed.

Note: Gear display indicators, messages, and tones will vary based on how the transmission system features and functions are configured in the Transmission Control module (TCM) and how the OEM has implemented them. Refer to OEM for more information on the dashboard display.

NOTICE: The default configuration for these functions in the Transmission Control Module (TCM) is Disabled unless Enabled at the OEM or body builder. The configuration can be changed using ServiceRanger.



WARNING: Failure to properly install the PTO and configure the TCM for PTO operation may result in major vehicle component damage, severe injury or death.



WARNING: Apply vehicle parking brake and follow OEM parking instructions. Failure to follow these instructions could cause unintended vehicle movement and may result in major vehicle component damage, property damage, severe injury or death.

Operation

Stationary PTO Operation

To engage a PTO for stationary operation:

1. Ensure the vehicle is at a complete stop.
2. Depress and hold the vehicle service brake pedal.
3. Select Neutral (N) mode using the transmission driver interface device.
4. Apply the vehicle parking brake and release the vehicle service brake pedal.
5. Switch the PTO switch to On.

Note: The PTO is active when the PTO switch is On. An indicator lamp is illuminated and/or message is displayed when the PTO is active.

To disengage the PTO:

1. Switch the PTO switch to Off.

Mobile PTO Operation

To engage a PTO for mobile operation:

1. Ensure the vehicle is at a complete stop.
2. Depress and hold the vehicle service brake pedal.
3. Select a non-neutral mode (Drive, Reverse, Manual) using the transmission driver interface device.
4. Switch the PTO switch to On.
5. Use the transmission driver interface device to Upshift or Downshift to the desired start gear.

Note: Shifting while vehicle is in motion is inhibited while the PTO is active.

6. Release the vehicle service brake pedal to allow for vehicle motion and to start PTO operation.

Note: The PTO is active when PTO switch is on, the vehicle service brake pedal is released and the vehicle is in motion. The PTO will stop when the vehicle is brought to a stop. An indicator lamp is illuminated and/or message is displayed when the PTO is active.

To disengage the PTO:

1. Ensure the vehicle is at a complete stop.
2. Depress and hold the vehicle service brake pedal.
3. Switch the PTO switch to Off.

Note: For Mobile PTO operation the transmission system automatically selects a start gear based on vehicle operating conditions such as: grade, load, and vehicle weight. Refer to “Smart Gear Selection” on page 20.

Split-Shaft PTO Operation

To engage the SSPTO:

1. Ensure the vehicle is at a complete stop.
2. Confirm engine speed is at idle RPM (500-700 RPM).
3. Depress and hold the vehicle service brake pedal.
4. Select Neutral (N) mode using the transmission driver interface device.
5. Apply the vehicle parking brake.
6. Switch the SSPTO switch to On.
7. Select Drive (D) mode using the transmission driver interface device.
8. Monitor the gear display to confirm full engagement of SSPTO default start gear (16th gear is factory default).

Note: A solid gear number indicates full gear engagement. A flashing gear number indicates gear is not engaged.

9. Release the vehicle service brake pedal to engage the driveline start SSPTO operation.
10. Increase engine speed to the desired SSPTO operating speed (1000-1200 RPM).

Note: The SSPTO default start gear (operating gear) configured in the Transmission Control Module (TCM) is 16th gear (direct drive). The configuration can be changed using ServiceRanger.

Note: Reverse (R) mode is configured in the TCM to Disabled by default in SSPTO mode to prevent vehicle equipment damage. If required by the vehicle application, Reverse (R) mode can be Enabled using ServiceRanger.

Note: An indicator lamp is illuminated and/or message is displayed when the SSPTO is active.

To select a different start gear (operating gear) for SSPTO operation:

1. Return engine speed to idle RPM (500-700 RPM).
2. Depress and hold the vehicle service brake pedal to disengage the driveline and stop SSPTO operation.
3. Use the transmission driver interface device to Upshift or Downshift to the desired start gear; select a higher gear for faster SSPTO operation or lower gear for slower SSPTO operation.

Note: The transmission driver interface device is an OEM component. Refer to OEM for more information on operation.

4. Release the vehicle service brake pedal to engage the driveline and restart SSPTO operation.
5. Increase engine speed to the desired SSPTO operating speed (1000-1200 RPM).

Note: The Transmission Control Module (TCM) can be configured to operate the SSPTO in one gear or a selected range of gears using ServiceRanger.

To disengage the SSPTO:

1. Return engine speed to idle RPM (500-700 RPM).
2. Depress and hold the vehicle service brake pedal to disengage the driveline and stop SSPTO operation.
3. Select Neutral (N) mode using the transmission driver interface device.
4. Switch the SSPTO switch to Off.

Auxiliary Transmission Operation

Note: Auxiliary Transmission Operation applies to Endurant XD Pro models only.

- The Endurant XD Pro transmission can be combined with a 2, 3 or 4-speed auxiliary transmission for additional gear ratio coverage. When auxiliary transmission gear engagement is complete and the vehicle driven, the transmission system learns the new auxiliary transmission gear ratios and adjusts transmission shift points as necessary.
- After initial installation of an auxiliary transmission the vehicle should be driven at a low constant speed in each of the auxiliary transmissions gears so the transmission system can immediately learn the overall ratio in each gear.

Note: Auxiliary transmission operation is configured in the Transmission Control Module (TCM) at the OEM or body builder. The configuration can be changed using ServiceRanger.



WARNING: Failure to properly install the auxiliary transmission and configure the transmission system for auxiliary transmission operation may result in major vehicle component damage, severe injury or death.

To operate with an auxiliary transmission:

1. Ensure the vehicle is at a complete stop.
2. Engage the auxiliary transmission using the appropriate driver interface device.
3. Launch and drive the vehicle normally.

Note: This process is repeated when an auxiliary transmission gear change is made.

Two-Speed Axle Operation

Note: Two-Speed Axle Operation applies to Endurant XD Pro models only.

- The Endurant XD Pro transmission can be combined with a 2-speed axle for additional gear ratio coverage. When 2-speed axle gear engagement is complete and the vehicle driven, the transmission system learns the new 2-speed axle gear ratios and adjusts transmission shift points as necessary.
- After initial installation of a 2-speed axle, it is recommended that the vehicle be driven at a low constant speed in each of the 2-speed axle gears so the transmission system can immediately learn the overall ratio in each gear.

Note: Two-speed axle operation is configured in the Transmission Control Module (TCM) at the OEM or body builder. The configuration can be changed using ServiceRanger.

To operate with a 2-speed axle:

1. Ensure the vehicle is at a complete stop.
2. Engage 2-speed axle using the appropriate driver interface device.
3. Launch and drive the vehicle normally.

Note: This process is repeated when a 2-speed axle gear change is made.

Transmission Oil Display Message

The transmission contains a fluid pressure sensor that monitors the transmission oil lubrication system pressure. If the sensor indicates a low oil condition to the Transmission Control Module (TCM) a transmission low oil message is displayed and an audible tone may be emitted.

If the transmission low oil message is displayed, perform the following as soon as possible or transmission damage may occur:

1. Continue to drive the vehicle to the nearest safe location.
2. Select Neutral (N) mode using the transmission driver interface device.
3. Apply the vehicle parking brake.

Note: Gear display indicators, messages, and tones will vary based on how the transmission system features and functions are configured in the Transmission Control Module (TCM) and how the OEM has implemented them. Refer to OEM for more information on the dashboard display.

Note: This feature is configured in the TCM with ServiceRanger.



WARNING: Apply vehicle parking brake and follow OEM parking instructions. Failure to follow these instructions could cause unintended vehicle movement and may result in major vehicle component damage, property damage, severe injury or death.

4. Turn ignition key to Off and allow the engine to shut down.
5. Contact a service facility to have the transmission system evaluated.

General Model Information

Serial Tag and Model Nomenclature

Transmission identification information is stamped on the serial tag located on the lower right side of the clutch housing.

When calling for service assistance or parts, have the model and serial numbers handy.

NOTICE: Do not remove or destroy the transmission identification tag.

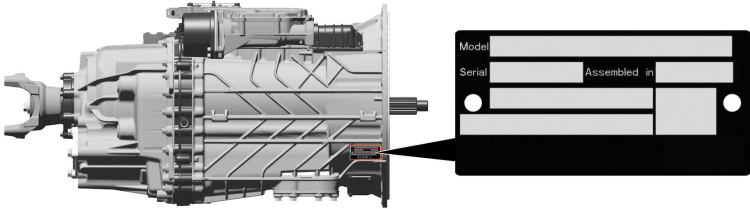

Model Number

The model number gives basic information about the transmission and is explained below.

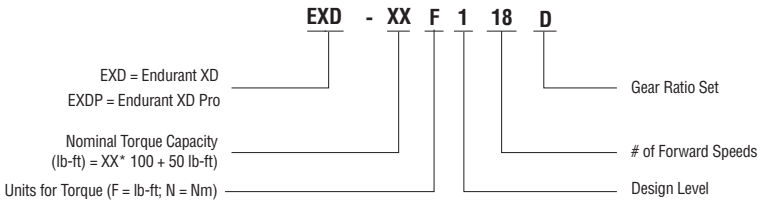

Serial Number

The serial number is the sequential identification number of the transmission.

Note: Record the Transmission Model and Serial Numbers in the blank spaces provided below.

Transmission Model _____

Transmission Serial Number _____

Troubleshooting

Diagnostics

In the event there is a problem with the transmission system, there are three primary tasks the driver should perform:

1. Note the driving condition under which the problem occurred.
2. Note the condition of the transmission under which the problem occurred (i.e. operation mode (Drive, MANUAL, LOW), current gear, engine speed, etc.).
3. Transmission Reset Procedure.

Transmission Reset Procedure

In some cases, proper transmission operation can be restored by “resetting” the Transmission Control Module (TCM). Use the following procedure to reset the TCM.

1. Continue to drive the vehicle to a safe location.
2. Select Neutral (N) mode using the transmission driver interface device.

Note: Once Neutral is selected, a gear engagement may not be allowed depending on the problem.

3. Apply the vehicle parking brake.



WARNING: Apply vehicle parking brake and follow OEM parking instructions. Failure to follow these instructions could cause unintended vehicle movement and may result in major vehicle component damage, property damage, severe injury or death.

4. Turn ignition key to Off and allow the engine to shut down.
5. Wait at least 2 minutes.
6. Restart the engine.
7. If the problem continues, contact a service facility to have the vehicle and transmission system evaluated.

Transmission Air Supply

For optimal performance, the transmission requires a nominal air supply operating range between 90 psi (620 kPA) and 130 psi (896 kPA). Air supply outside this range can result in degraded or complete loss of transmission engagement and shift capabilities.



CAUTION: Vehicle air quality is important for transmission system operation. Failure to follow the vehicle air system maintenance requirements may result in transmission damage; this voids the transmission warranty. Refer to OEM guidelines for vehicle air and filter system maintenance.

Proper Transmission Lubrication

Proper lubrication procedures are key to a good all-around maintenance program. If the lubricant is not doing its job or if the lubricant level is ignored, all the maintenance procedures in the world are not going to keep the transmission running or assure long transmission life.

Transmission internal parts are amply lubricated if these procedures are closely followed:

1. Maintain lubricant level and inspect regularly.
2. Follow maintenance interval chart.
3. Use the correct grade and type of lubricant.
4. Buy lubricant from an approved dealer.

Lubrication Specifications

Use only Eaton approved lubricant. For information, see *Eaton Lubrication Product Specification Manual (TCMT0021)*.

 **CAUTION:** Failure to use the approved lubricant will affect the transmission performance and the warranty coverage.

 **CAUTION:** Additives and/or friction modifiers are not approved. Additives of any kind will affect the transmission performance and the warranty coverage.

For a list of Eaton approved lubricant suppliers, see *Eaton Approved Lubricant Suppliers Lubrication Guide (TCMT0020)*.

Transmission Oil Level Inspection Procedure

1. Park vehicle in a safe area on level ground.
2. Key off.
3. Apply the vehicle parking brake and chock wheels.



WARNING: Apply vehicle parking brake and follow OEM parking instructions. Failure to follow these instructions could cause unintended vehicle movement and may result in major vehicle component damage, property damage, severe injury or death.

4. Locate the transmission check plug on the left side of the rear housing.
5. Place a suitable container under the Oil Check Plug and remove the check plug with a 6 mm hex key.
6. Oil level is correct when a small amount of oil runs out of the Oil Check Plug hole.

Note: If oil level is low, check for leaks (repair if necessary) and reference *Endurant XD Series Automated Transmission Service Manual (TRSM0960)*, Oil Service Procedure, Fill Oil.

7. Inspect the Oil Check Plug and O-ring for damage. If damaged, replace the Oil Check Plug; O-ring is serviced with plug.
8. Install the Oil Check Plug and torque to 24.5-29.5 Nm (18-22 lb-ft).

Service and Maintenance

NOTICE: Do not over-torque the Oil Check Plug or transmission damage may occur.

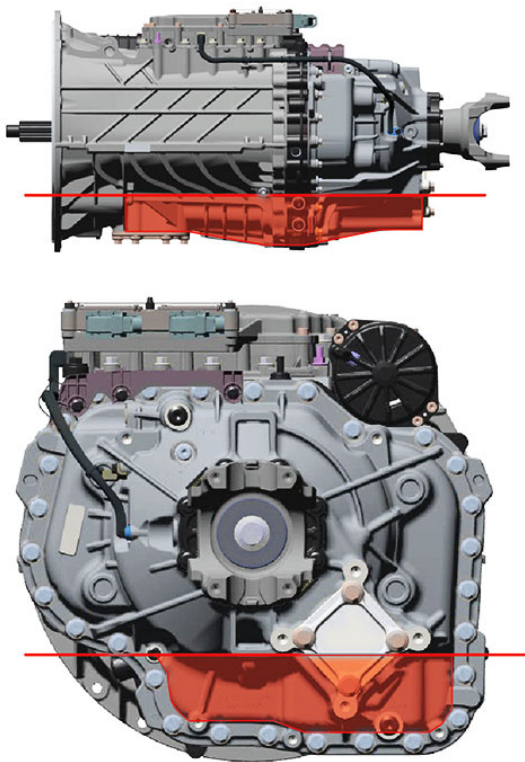

CAUTION: Do not operate the transmission at an operating angle greater than 12° (approximately a 21% grade) or improper lubrication will occur causing damage to the transmission. The operating angle is the transmission mounting angle in the chassis plus the percent of upgrade (expressed in degrees)

Transmission Lubrication Change Intervals

Lubricant changes should be based on the intervals shown in *Eaton Lubrication Product Specification Manual (TCMT0021)*. Extending drain intervals beyond those indicated are not recommended and will affect the transmission performance and the warranty coverage.

Vehicle Towing

When towing the vehicle, do not allow the output shaft of the transmission to rotate. If the vehicle is towed with the drive wheels still in contact with the road surface, the vehicle axle shafts or driveline must be removed or disconnected prior to towing vehicle.



CAUTION: Failure to follow the Vehicle Towing procedure will result in transmission damage and voids the transmission warranty.

Preferred

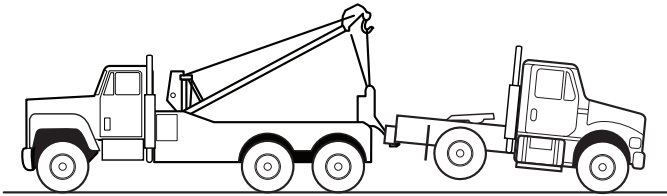

Must remove vehicle axle shafts or driveline prior to towing



Limited Driveline-Connected Towing

In an urgent situation and after specified vehicle and transmission system requirements are met, the vehicle may be towed a limited distance at a limited road speed and with the driveline connected and the drive wheels in contact with the road surface.

 **CAUTION:** Failure to follow the Limited Driveline-Connected Towing requirements listed below will result in transmission damage and voids the transmission warranty.

Vehicle and Transmission System Requirements:

- Vehicle air pressure greater than 90 psi (620 kPA)
- Neutral (N) selected on the transmission driver interface device
- Solid Neutral (N) indicator on the vehicle's transmission driver interface device
- Solid "N" is indicated in the gear display
- Key off

Limited Towing Speed and Distance Requirements:

- Road speed less than 25 mph (40 km/h)
- Distance less than 0.25 mile (0.40 km)

Dynamometer Test Mode

In cases when vehicle dynamometer testing is required, the transmission system can be put into a dynamometer test mode.

Note: Transmission Control Module (TCM) software 5516062 or greater is required to support dynamometer test mode.

Use the following procedure to activate Dynamometer Test Mode in the TCM.



WARNING: Refer to dynamometer manufacturer's instructions regarding vehicle setup and testing. Failure to follow these instructions could cause unintended vehicle movement and may result in major vehicle component damage, property damage, severe injury or death.

Vehicle and Transmission System Requirements:

- Key on with engine off.
- Ensure the vehicle is at a complete stop.
- Neutral (N) is selected on the transmission driver interface device.
- Solid "N" is indicated in the gear display.

To activate Dynamometer Test Mode:

1. Key on with engine off.
2. Depress and hold the vehicle service brake pedal.
3. Perform the following sequence using the transmission driver interface device within 20 seconds.
 - a. Start in Neutral (N)
 - b. Select Drive (D)
 - c. Select Manual Mode (M)
 - d. Select Drive (D)
 - e. Select Reverse (R)
 - f. Select Drive (D)
 - g. Select Neutral (N)

Service and Maintenance

4. When complete, a 12 second audible tone indicates Dynamometer Test Mode is active in the TCM.
5. Perform required vehicle dynamometer testing.
6. When vehicle dynamometer testing is complete, key off to deactivate Dynamometer Test Mode.

Note: Gear display indicators, messages, and tones will vary based on how the transmission system features and functions are configured in the Transmission Control Module (TCM) and how the OEM has implemented them. Refer to OEM for more information on the dashboard display.



WARNING: Failure to follow these instructions could cause unintended vehicle movement and may result in major vehicle component damage, property damage, severe injury or death.

Copyright Eaton Cummins Automated Transmission Technologies, 2023. Eaton Cummins Automated Transmission Technologies hereby grant their customers, vendors, or distributors permission to freely copy, reproduce and/or distribute this document in printed format. It may be copied only in its entirety without any changes or modifications. THIS INFORMATION IS NOT INTENDED FOR SALE OR RESALE, AND THIS NOTICE MUST REMAIN ON ALL COPIES.

Note: Features and specifications listed in this document are subject to change without notice and represent the maximum capabilities of the software and products with all options installed. Although every attempt has been made to ensure the accuracy of information contained within, Eaton makes no representation about the completeness, correctness or accuracy and assumes no responsibility for any errors or omissions. Features and functionality may vary depending on selected options.

For spec'ing or service assistance, call 1-800-826-HELP (4357) or visit www.eaton.com/roadranger. In Mexico, call 001-800-826-4357.

Roadranger: Eaton and trusted partners providing the best products and services in the industry, ensuring more time on the road.

Eaton Cummins Automated Transmission Technologies
P.O. Box 4013
Kalamazoo, MI 49003 USA
800-826-HELP (4357)
www.eaton.com/roadranger

Printed in USA



BACKED BY
Roadranger
SUPPORT